

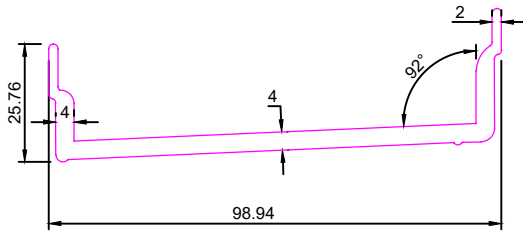

UNITIZED SYSTEM

SEC No. 7128

Weight :-5.240kg/12'



SEC No. 7129

Weight :- 9.100kg/12'

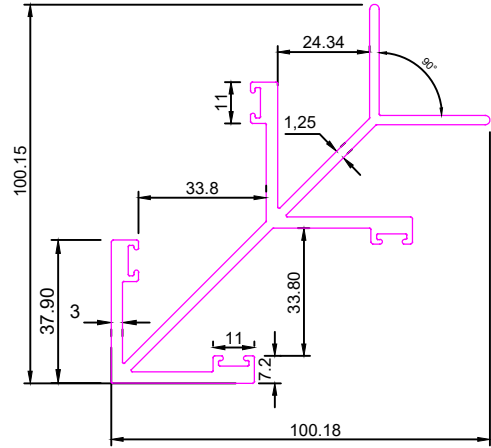

SEC No. 7130

Weight :-9.00kg/12'

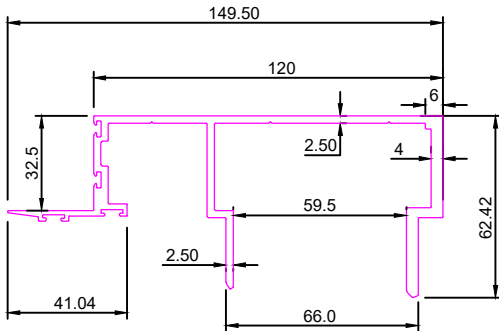

SEC No. 7131

Weight :- 6.695kg/12'

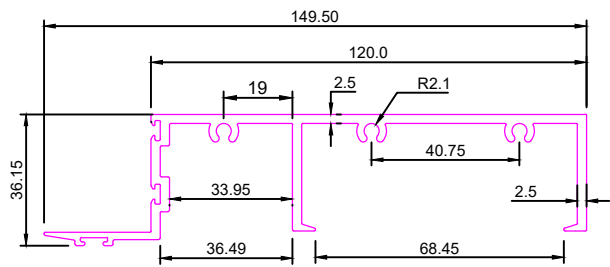

SEC No. 7132

Weight :-7.100kg/12'

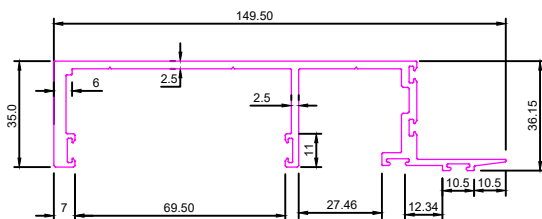

SEC No. 7133

Weight :-8.250kg/12'

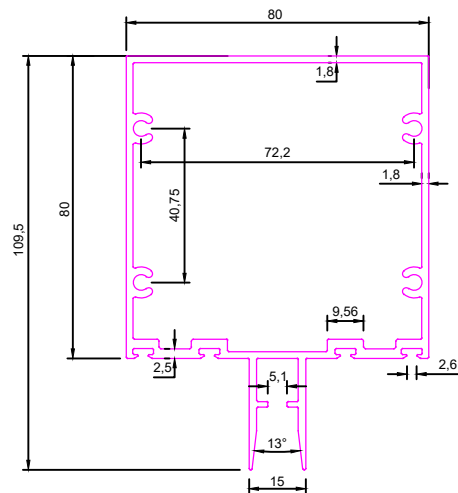



UNITIZED SYSTEM

SEC No. 7134

Weight :- 11.850kg/12'

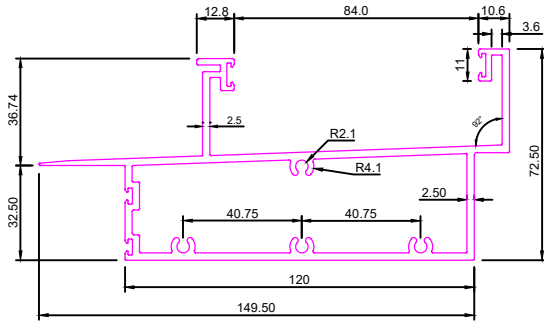

SEC No. 7135

Weight :-13.700kg/12'

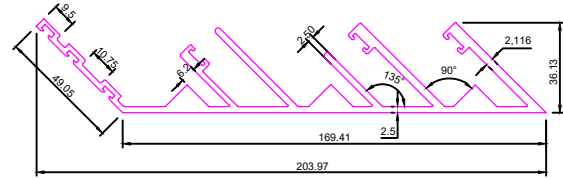

SEC No. 7136

Weight :-10.450kg/12'

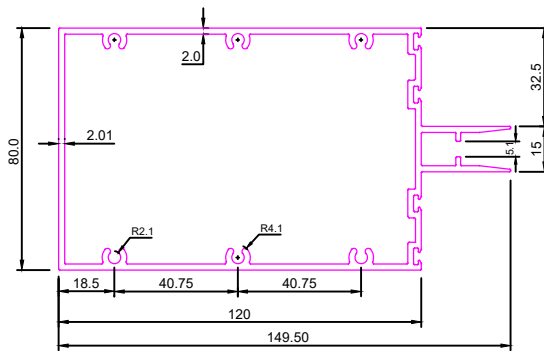

SEC No. 7137

Weight :-1.050kg/12'

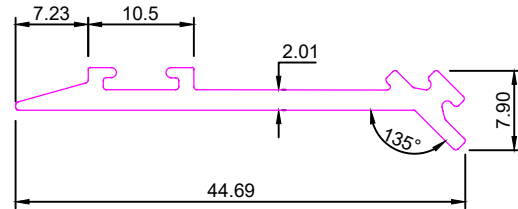

SEC No. 7250

Weight :-14.940kg/12'

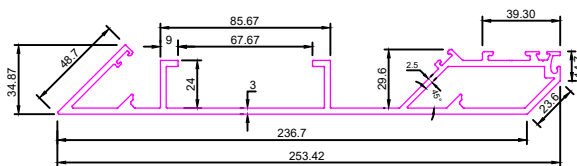

SEC No. 7251

Weight :-18.375kg/12'

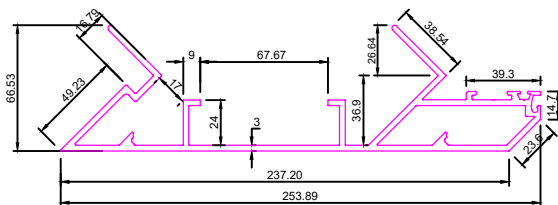



UNITIZED SYSTEM

SEC No.7444

Weight :-6.700kg/12'

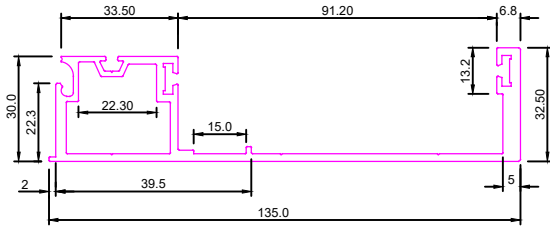

SEC No.7445

Weight :-8.650kg/12'

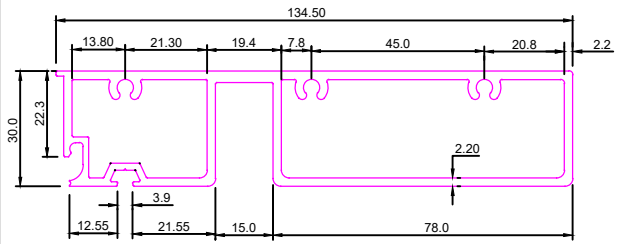

SEC No.7446

Weight :-8.250kg/12'

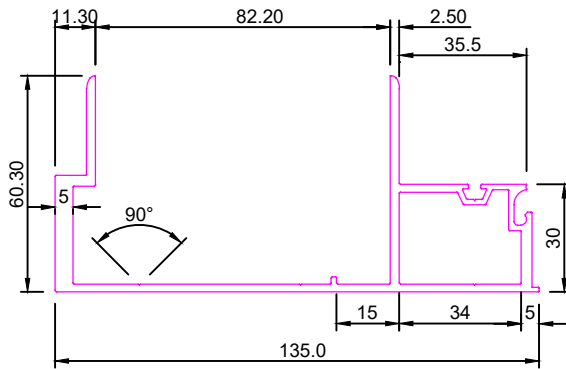

SEC No.7447

Weight :-11.700kg/12'

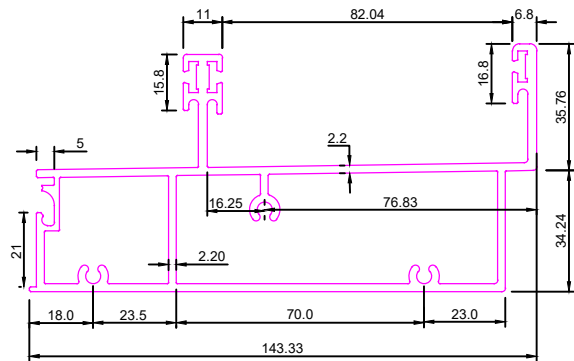

SEC No. 7456

Weight :- 12.00kg/12'

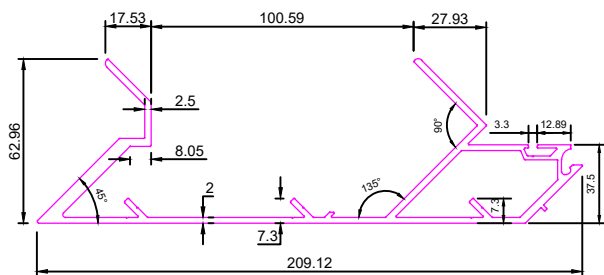

SEC No. 7457

Weight :-9.775kg/12'

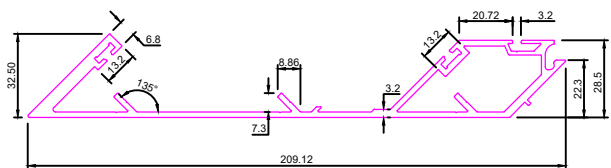



UNITIZED SYSTEM

SEC No. 7478

Weight :-11.370kg/12'

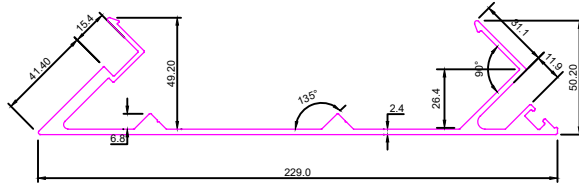

SEC No. 7479

Weight :-11.445kg/12'

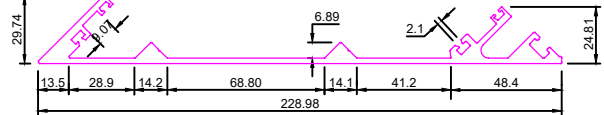

SEC No. 7515

Weight :-16.00kg/12'

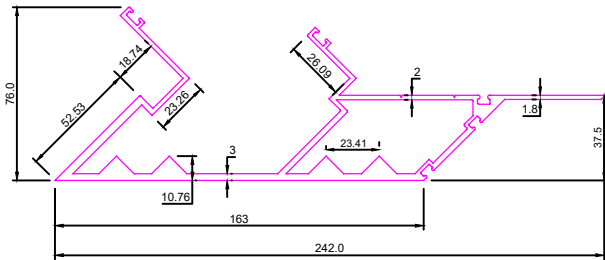

SEC No. 7516

Weight :-13.950kg/12'

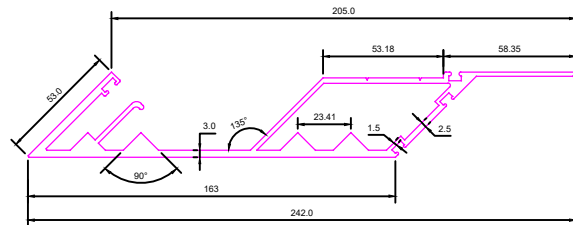

SEC No. 7669

Weight:-18.600Kg/12'

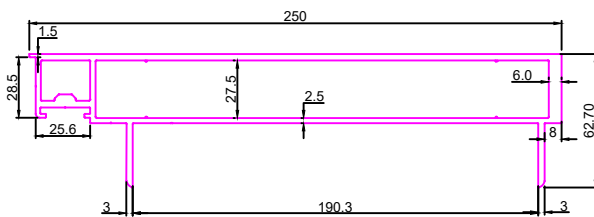

SEC No. 7670

Weight:-17.400Kg/12'

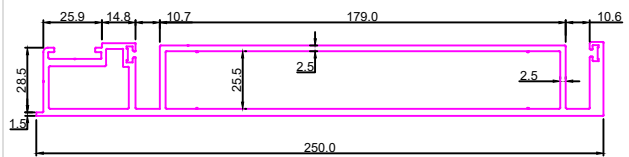



UNITIZED SYSTEM

SEC No. 7676

Weight:-13.850Kg/12'

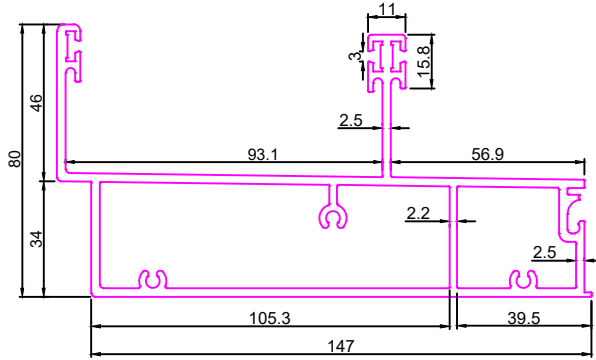

SEC No. 7677

Weight:-11.500Kg/12'

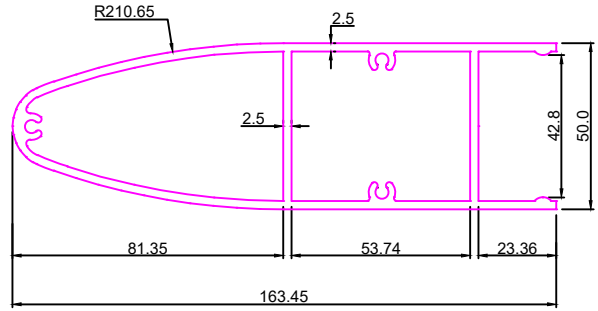

SEC No. 7678

Weight:-11.550Kg/12'

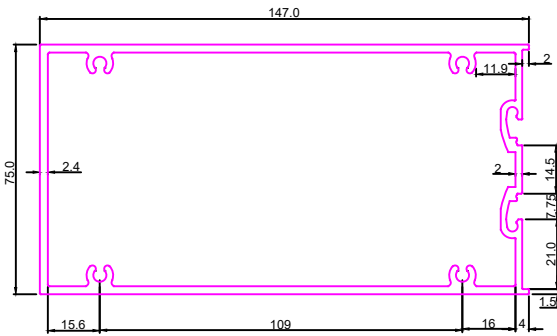

SEC No. 7679

Weight:-13.650Kg/12'

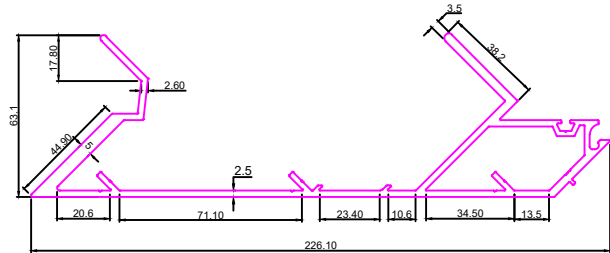

SEC No. 7680

Weight:-11.750Kg/12'

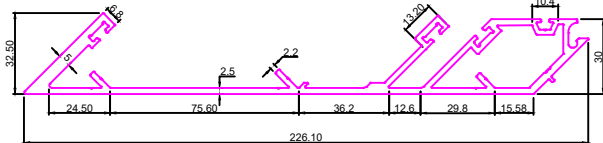

SEC No. 7751

Weight:-15.700Kg/12'

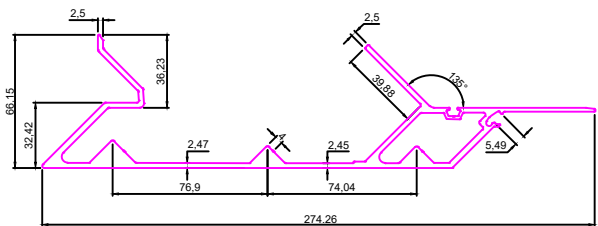



UNITIZED SYSTEM

SEC No. 7752

Weight:-15.250Kg/12'

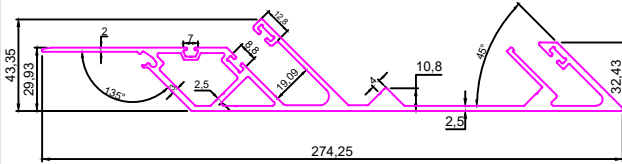

SEC No. 7761

Weight:-8.650Kg/12'

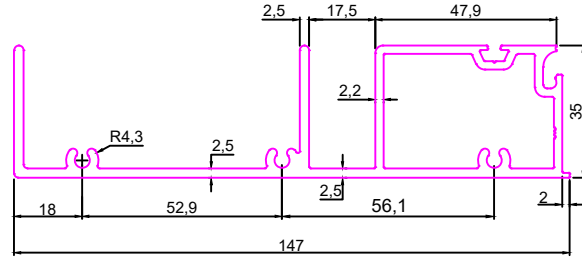

SEC No. 7762

Weight:-8.350Kg/12'

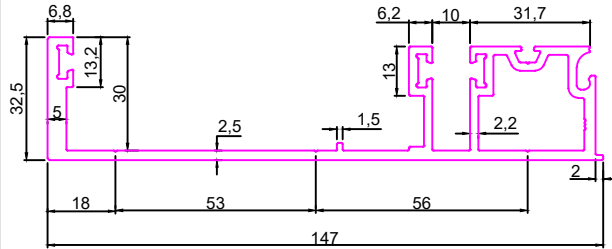

SEC No. 7763

Weight:-9.500Kg/12'

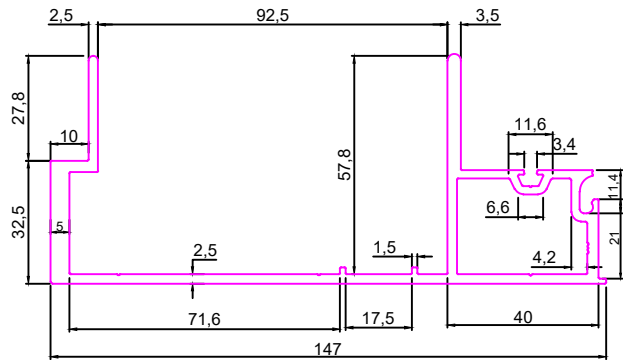

SEC No. 7764

Weight:-8.750Kg/12'

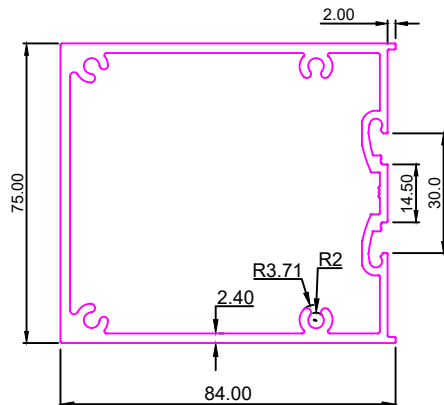

SEC No. 7765

Weight:-22.745Kg/12'

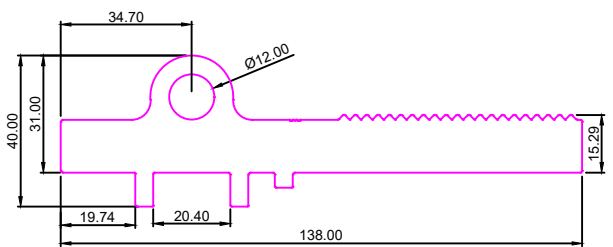



UNITIZED SYSTEM

SEC No. 7766

Weight:-1.755Kg/12'

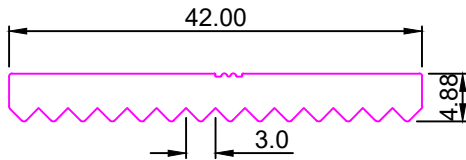

SEC No. 7767

Weight:-16.00Kg/12'

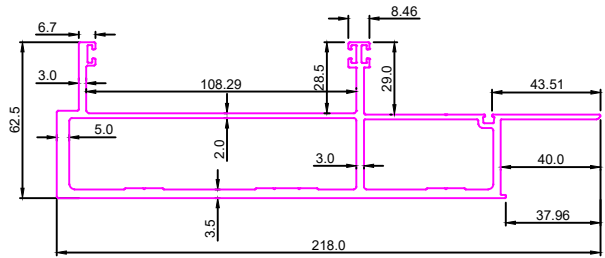

SEC No. 7768

Weight:-15.600Kg/12'

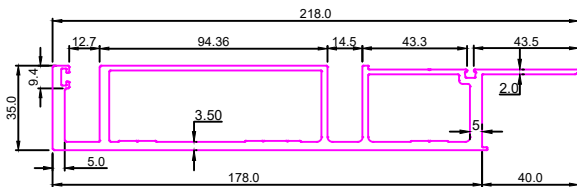

SEC No. 7769

Weight:-11.450Kg/12'

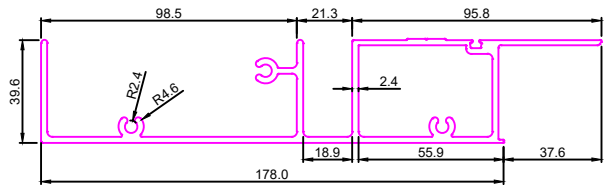

SEC No. 7770

Weight:-16.900Kg/12'

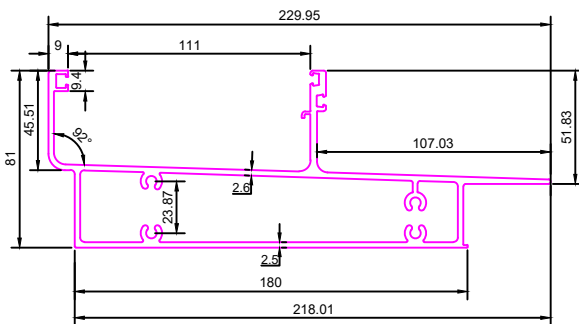

SEC No. 7818

Weight:-8.500Kg/12'

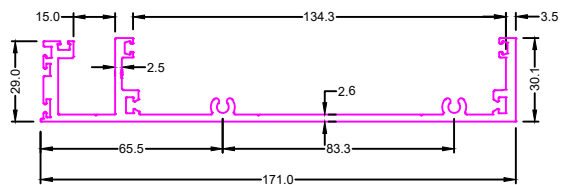



UNITIZED SYSTEM

SEC No. 7819

Weight:-9.150Kg/12'

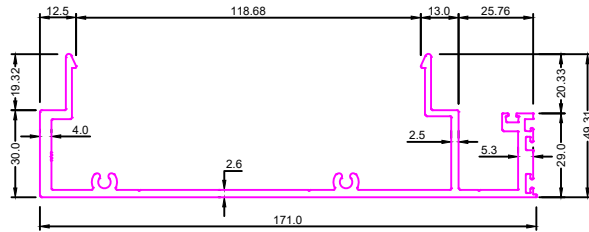

SEC No. 7846

Weight:-18.500Kg/12'

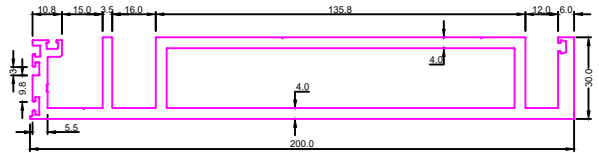

SEC No. 7847

Weight:-13.935Kg/12'

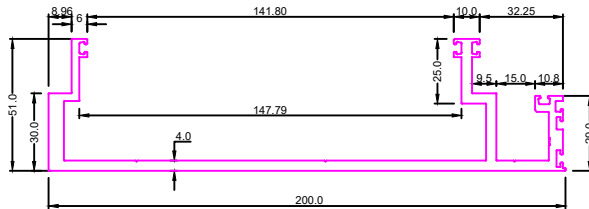

SEC No. 7848

Weight:-17.900Kg/12'

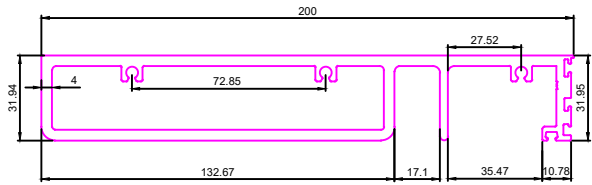

SEC No. 7849

Weight:-22.545Kg/12'

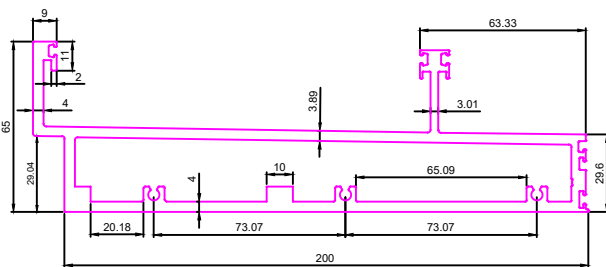

SEC No. 7859

Weight:-11.350Kg/12'

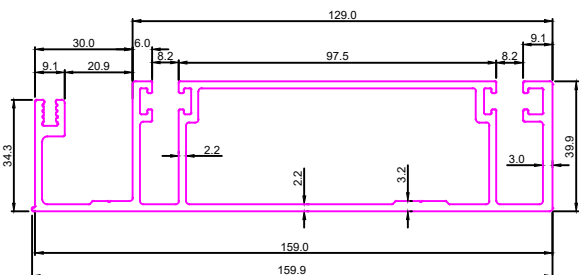



UNITIZED SYSTEM

SEC No. 7860

Weight:-11.000Kg/12'

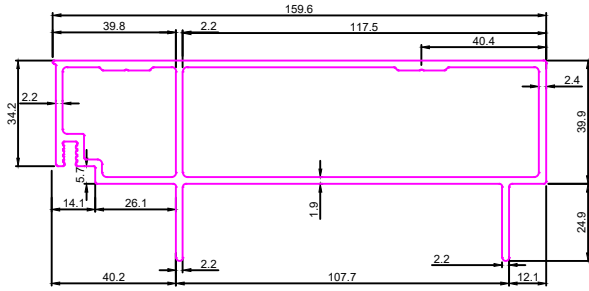

SEC No. 7876

Weight:8.888Kg/12'

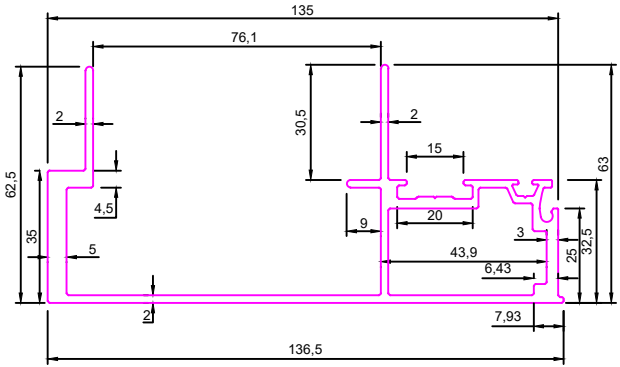

SEC No. 7877

Weight:10.050Kg/12'

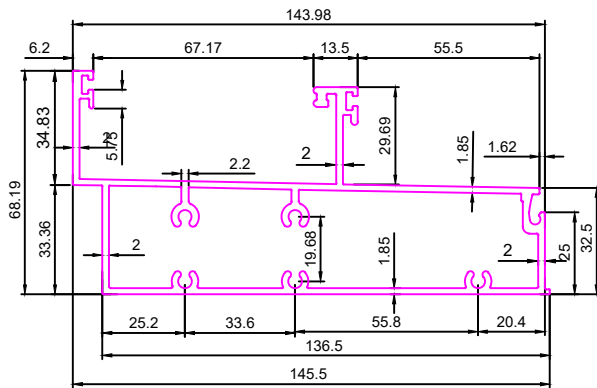

SEC No. MA7920

Weight:-7.735Kg/12'

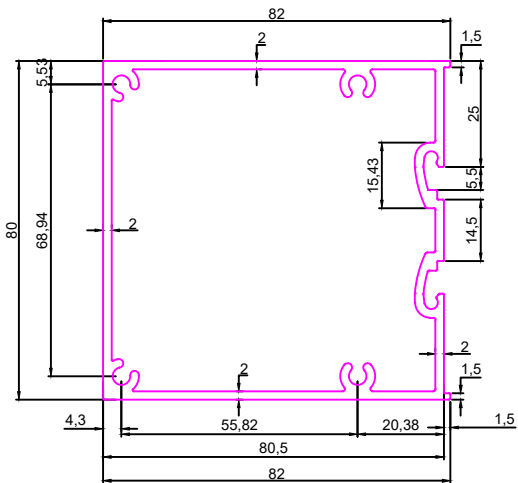

SEC No. MA7930

Weight:-6.700Kg/12'

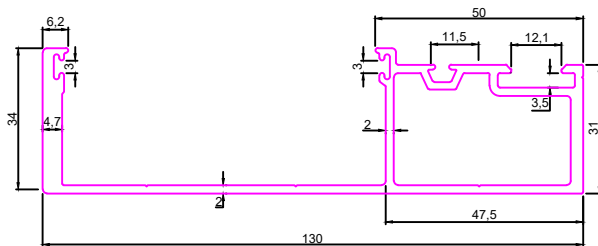

SEC No. MA7931

Weight:-8.900Kg/12'

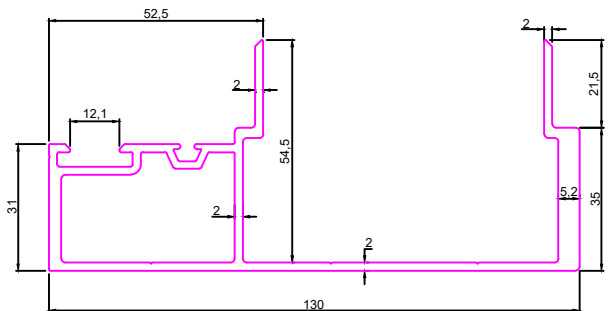



UNITIZED SYSTEM

SEC No. MA7932

Weight:-8.100Kg/12'

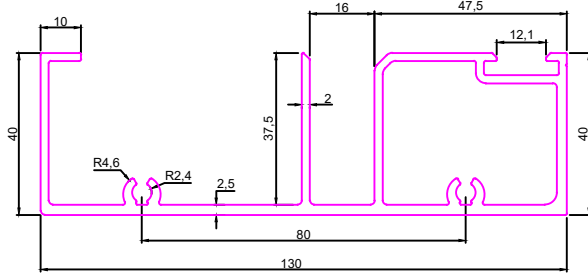

SEC No. MA7933

Weight:-9.600Kg/12'

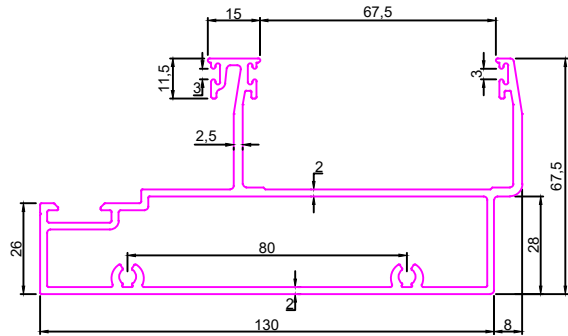

SEC No. MA7934

Weight:-3.200Kg/12'

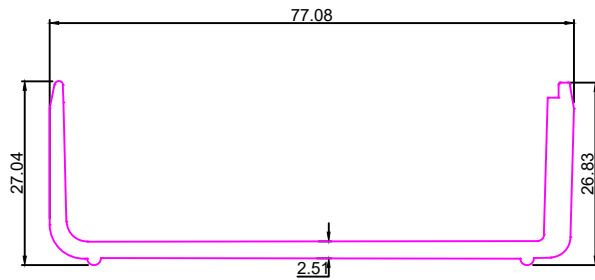

SEC No. MA7935

Weight:1.050Kg/12'

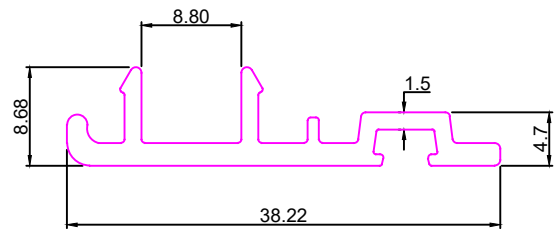

SEC No. 7937

Weight:2.050Kg/12'

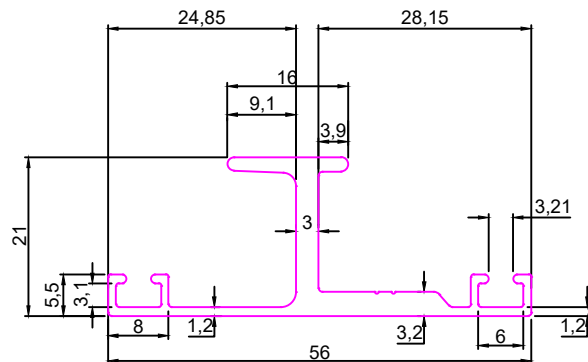

SEC No. 8624

Weight:4.970Kg/12'

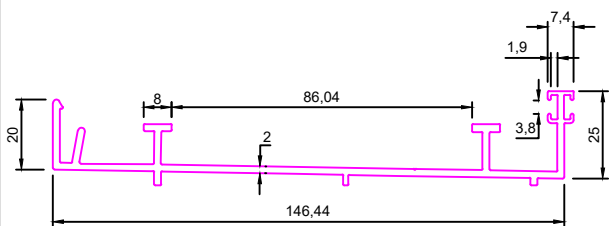



UNITIZED SYSTEM

SEC No. 8625

Weight:1.650Kg/12'

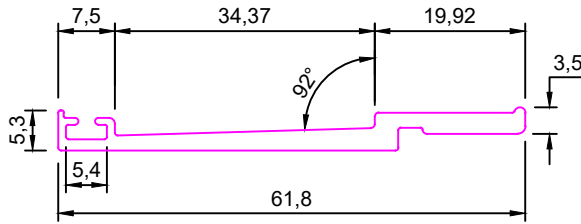

SEC No. 8626

Weight:4.900Kg/12'

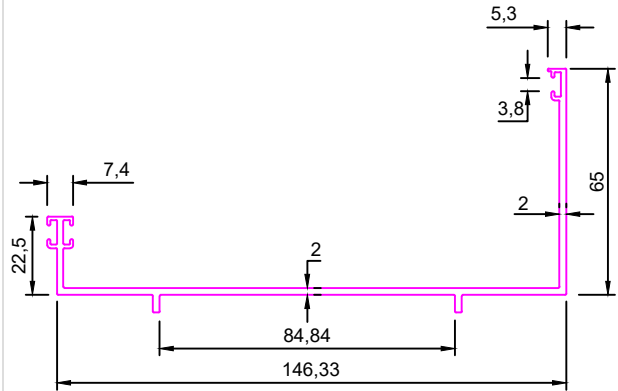

SEC No. 8628

Weight:7.285Kg/12'

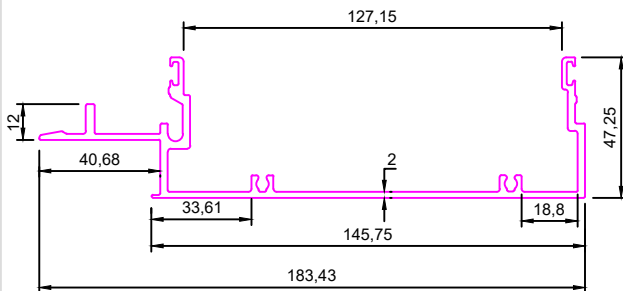

SEC No. 8629

Weight:6.000Kg/12'

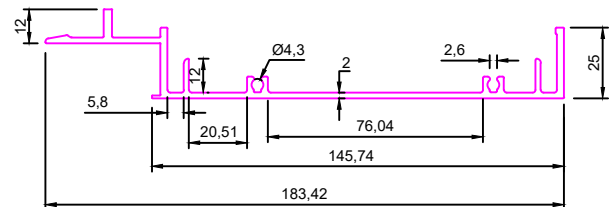

SEC No.:-8801

Weight:-17.175Kg/12'

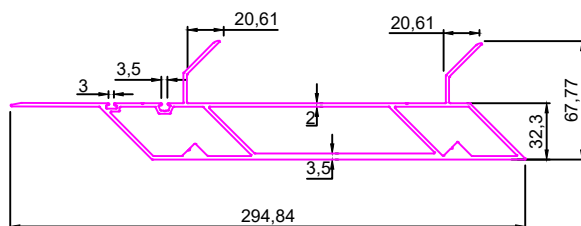

SEC No.:-8802

Weight:-16.900Kg/12'

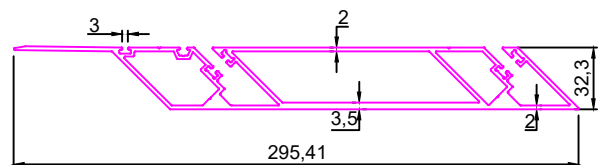



UNITIZED SYSTEM

SEC No.:-8803

Weight:-12.250Kg/12'

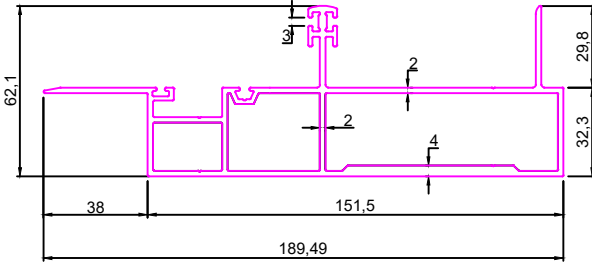

SEC No.:-8804

Weight:-9.600Kg/12'

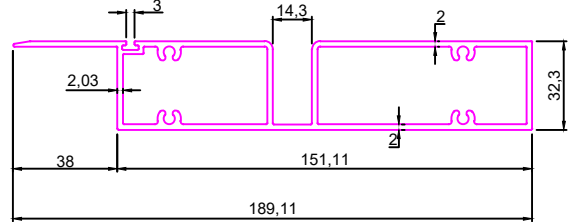

SEC No.:-8805

Weight:-10.800Kg/12'

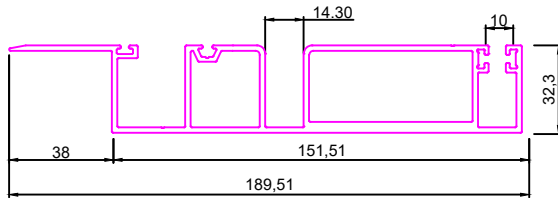

SEC No.:-8806

Weight:-11.335Kg/12'

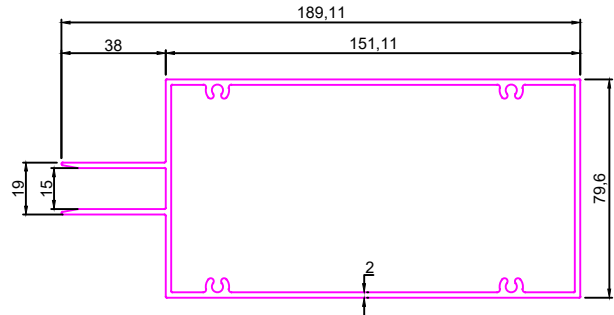

SEC No.:-8807

Weight:-12.480Kg/12'

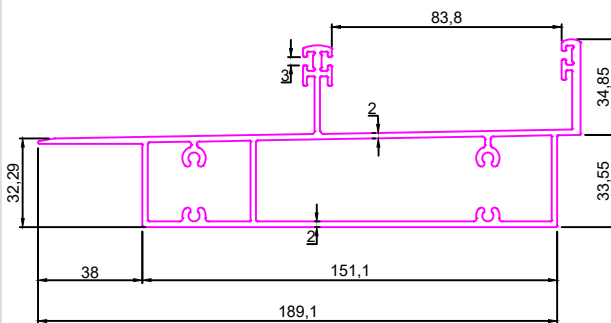

SEC No.:-8808

Weight:-4.185Kg/12'

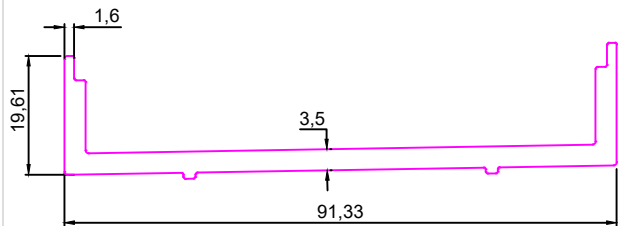



UNITIZED SYSTEM

SEC No.:-8809

Weight:-2.095Kg/12'

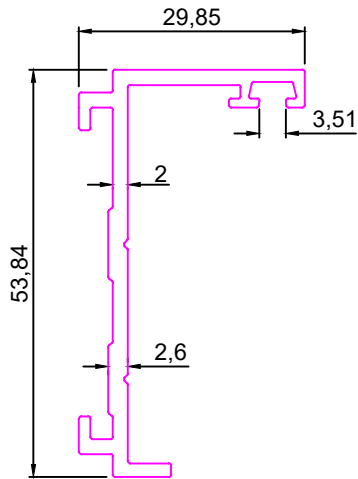

SEC No.:-8810

Weight:-5.140Kg/12'

