



Sliding



Sliding window

Index Box

Sr. No.	Profile Name	Page Number	Remarks
1.	18x40 Sliding Series	1 - 5	5 Pages
2.	18x48 Sliding Series	6	1 Page
3.	18x50 Sliding Series	7	1 Page
4.	18x60 Sliding Series	8	1 Page
5.	20mm Sliding Series	9 - 10	2 Pages
6.	25mm Sliding Series	11 - 14	4 Pages
7.	30mm Sliding Series	15 - 17	3 Pages
8.	50mm Sliding Series	18	1 Pages
8.	Sliding	19 - 25	7 Pages
9.	Sliding Window	25 - 42	17 Pages





18X40 SLIDING SERIES

3/4" HANDLE

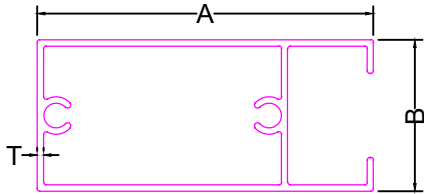

SECTION NO	A	B	T	Weight (Kg/12')
2100	40.00	18.00	0.65	0.800-0.900
2101	40.00	18.00	0.75	1.000-1.200
2102	40.00	18.00	1.10	1.400-1.600
2103	40.00	18.00	1.12	1.500-1.700
2104	40.00	18.00	1.20	1.800-2.000

3/4" TOP BOTTOM

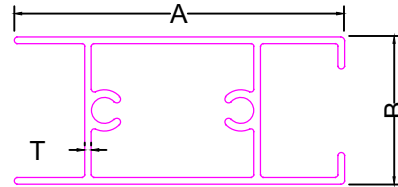

SECTION NO	A	B	T	Weight (Kg/12')
2121	40.00	18.00	0.65	0.800-1.000
2122	40.00	18.00	0.80	1.000-1.200
2123	40.00	18.00	1.15	1.400-1.600
2124	40.00	18.00	1.20	1.550-1.750
2125	40.00	18.00	1.50	1.800-2.000

3/4" MATTING

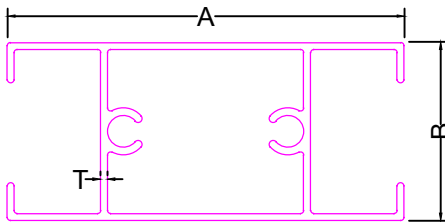

SECTION NO	A	B	T	Weight (Kg/12')
2141	40.00	18.00	0.75	1.100-1.200
2142	40.00	18.00	0.95	1.300-1.500
2143	40.00	18.00	1.15	1.500-1.700

3/4" BEARING BOTTOM

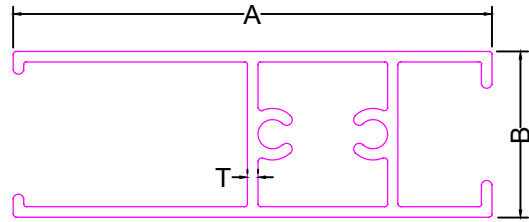

SECTION NO	A	B	T	Weight (Kg/12')
2161	52.00	18.00	0.85	1.200-1.500
2162	52.00	18.00	1.20	1.800-2.000

3/4" INTERLOCK

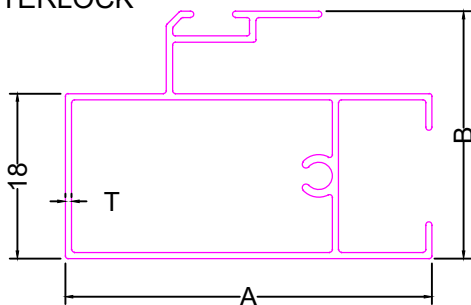

SECTION NO	A	B	T	Weight (Kg/12')
2181	40.00	27.00	0.70	1.100-1.200
2182	40.00	27.00	0.80	1.200-1.400
2183	40.00	27.00	0.95	1.400-1.600
2184	40.00	27.00	1.20	1.800-2.000
2185	40.00	27.00	1.50	2.100-3.000

SEC NO. :-2201

Weight :- 1.000kg/12'

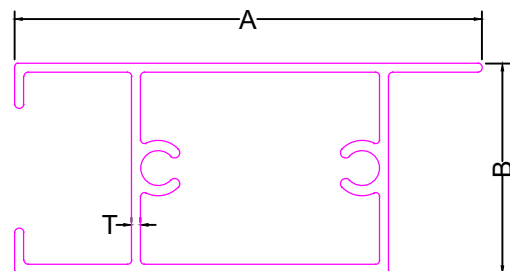

3/4" SINGLE LEG BOTTOM



18X40 SLIDING SERIES

SEC NO. :-2211

Weight :- 0.825kg/12'

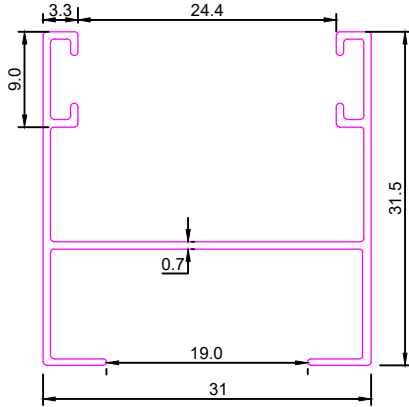

SEC NO. :-2231

Weight :- 0.950kg/12'

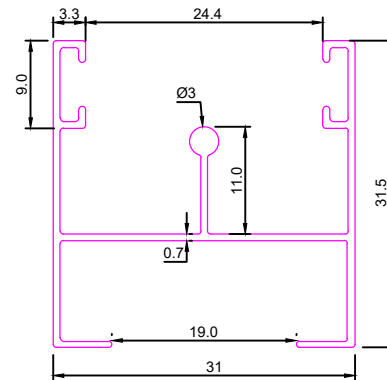

¾" 2 TRACK TOP

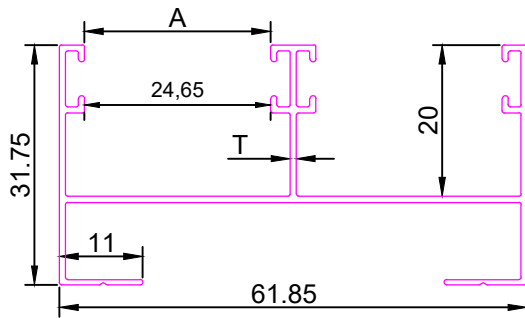

¾" 2 TRACK BOTTOM

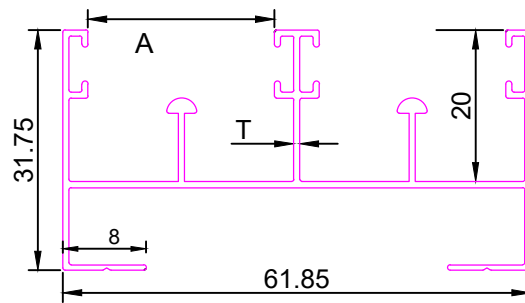

Sr No.	SECTION NO.	A	B	T	Weight (Kg/12')
1	2231	61.85	31.75	0.60	1.100-1.300
2	2232	61.85	31.75	0.70	1.400-1.600
3	2233	61.85	31.75	0.85	1.500-2.000
4	2234	61.85	31.75	1.00	2.000-2.200
5	2235	61.85	31.75	1.20	2.400-2.600
6	2236	61.85	31.75	1.50	2.800-3.000

Sr No.	SECTION NO.	A	B	T	Weight (Kg/12')
1	2241	61.85	31.75	0.60	1.400-1.600
2	2242	61.85	31.75	0.80	1.800-2.000
3	2243	61.85	31.75	0.95	2.100-2.300
4	2244	61.85	31.75	1.20	2.600-2.800
5	2245	61.85	31.75	1.50	3.200-3.400

SEC NO. :-2251

Weight :- 1.700kg/12'

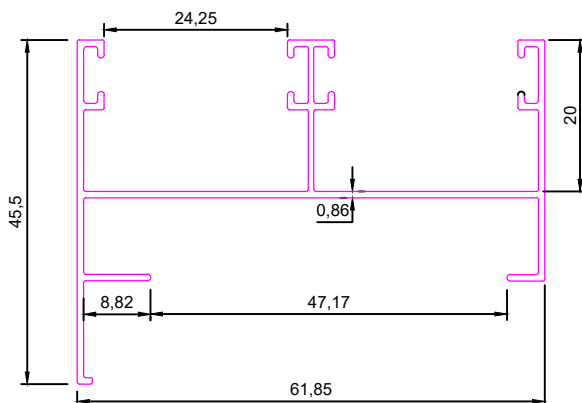

SEC NO. :-2261

Weight :- 1.970kg/12'

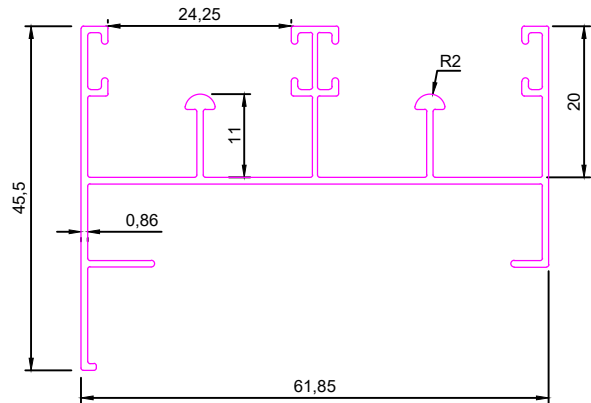



18X40 SLIDING SERIES

3/4" 3 TRACK TOP

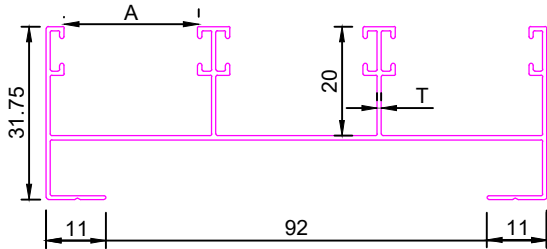

Sr. No.	SECTION NO.	A	B	T	Weight (Kg/12')
1	2271	92	31.75	0.70	1.800-2.000
2	2272	92	31.75	0.80	2.000-2.300
3	2273	92	31.75	0.93	2.400-2.600
4	2274	92	31.75	1.10	2.700-3.000
5	2275	92	31.75	1.20	3.000-3.200
6	2276	92	31.75	1.50	4.000-4.200

3/4" 3 TRACK BOTTOM

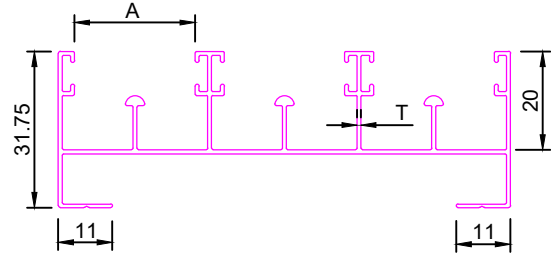

SL NO.	SECTION NO.	A	B	T	WT. RANGE KG/12'
1	2281	92	31.75	0.73	2.200-2.400
2	2282	92	31.75	0.80	2.500-2.700
3	2283	92	31.75	0.95	2.800-3.000
4	2284	92	31.75	1.20	3.000-3.300
5	2285	92	31.75	1.50	3.500-3.700
6	2286	92	31.75	1.50	4.200-4.400

3/4" 4 TRACK TOP

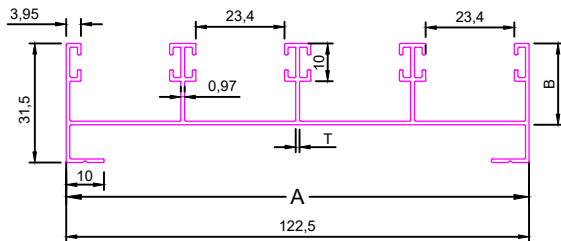

Sr. No.	SECTION NO.	A	B	T	Weight (Kg/12')
1	2291	122.5	31.5	0.80	2.800-3.000
2	2292	122.5	31.5	0.90	3.000-3.300
3	2293	122.5	31.5	1.05	3.500-3.700
4	2294	122.5	31.5	1.50	5.000-5.300

3/4" 4 TRACK BOTTOM

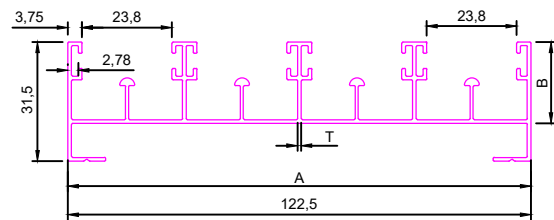

Sr. No.	SECTION NO.	A	B	T	Weight (Kg/12')
1	2301	122.5	31.5	0.95	3.800-4.000
2	2302	122.5	31.5	1.05	4.000-4.200
3	2303	122.5	31.5	1.50	6.200-6.500



18X40 SLIDING SERIES

SEC NO. :-3261

3/4" 5 TRACK TOP

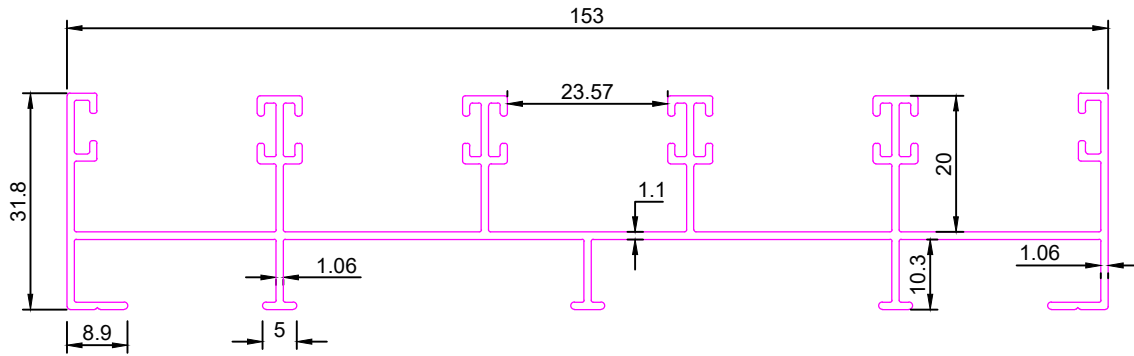

Sr. No.	SECTION NO.	A	B	T	Weight (Kg/12')
1	2311	153	31.80	0.95	4.400-4.800
2	2312	153	31.80	1.10	5.800-5.600
3	2313	153	31.80	1.50	6.400-6.800

SEC NO. :-3271

3/4" 5 TRACK BOTTOM

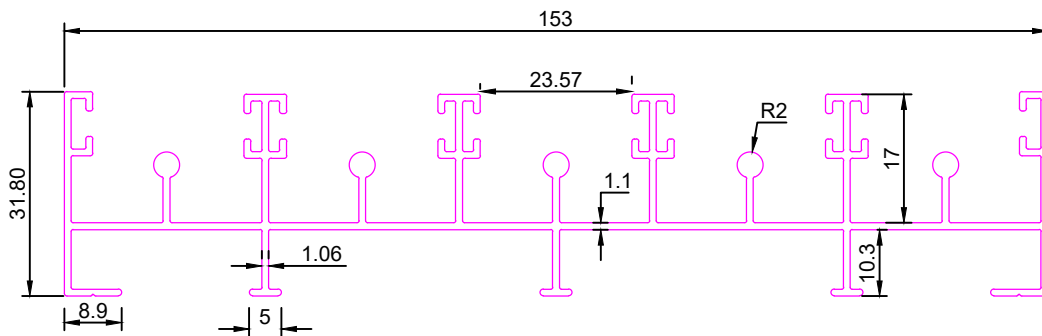

SL NO.	SECTION NO.	A	B	T	WT. RANGE KG/12'
1	2321	153	31.80	0.95	5.000-5.500
2	2322	153	31.80	1.10	5.800-6.300
3	2323	153	31.80	1.50	7.300-7.700



18X40 SLIDING SERIES

SEC NO. :-2331

Weight :- 3.715kg/12'

3/4" 2 TRACK BOTTOM (HOLLOW)

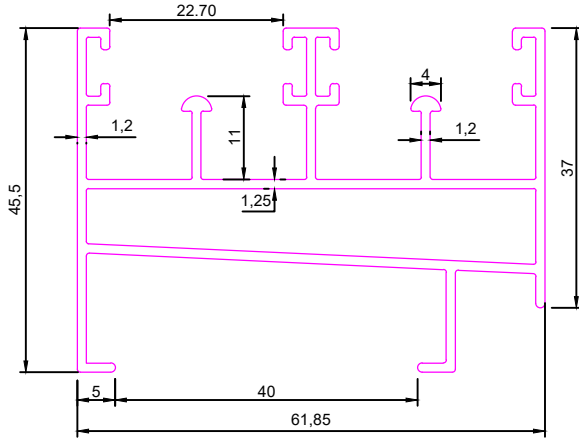

SEC NO. :-2341

Weight :- 4.200kg/12'

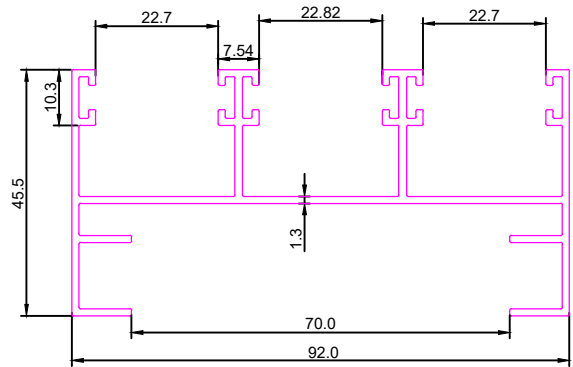

SEC NO. :-2351

Weight :- 5.075kg/12'

3/4" 3 TRACK BOTTOM (HOLLOW)

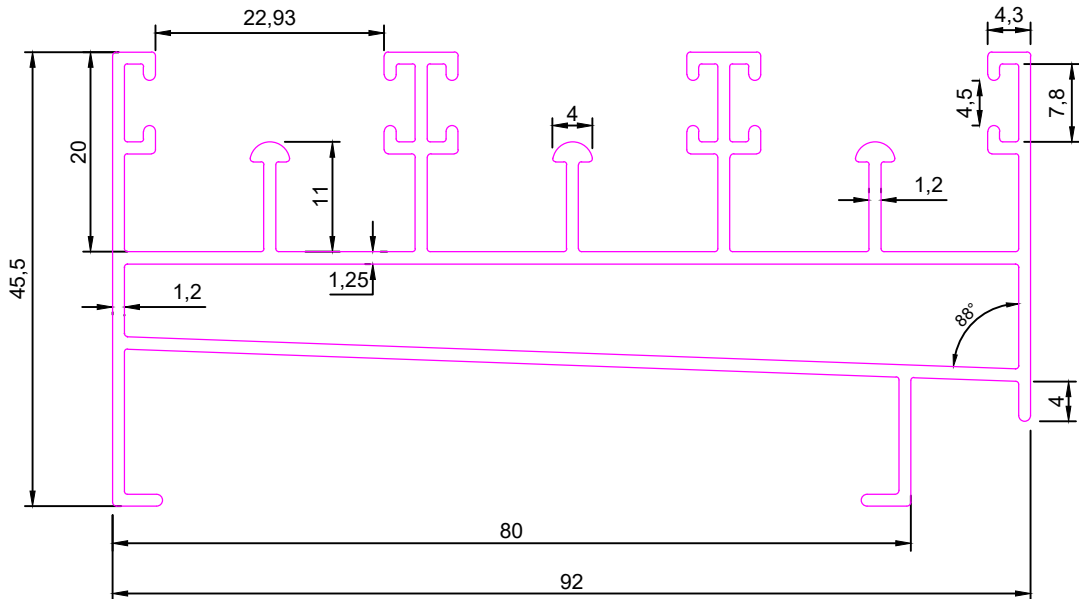



18X48 SLIDING SERIES

SEC NO. :-2691

Weight :- 1.200kg/12'

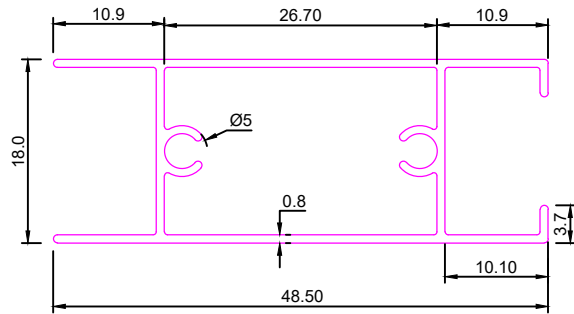

SEC NO. :-2696

Weight :- 1.430kg/12'

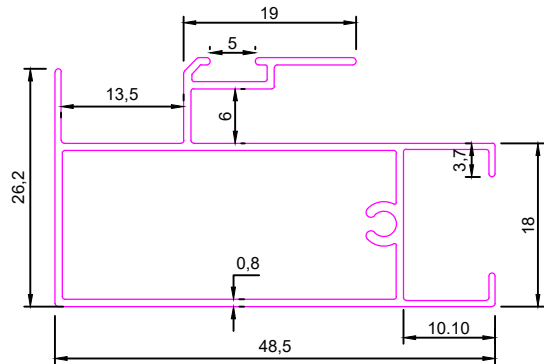

SEC NO. :-2701

Weight :- 1.200kg/12'

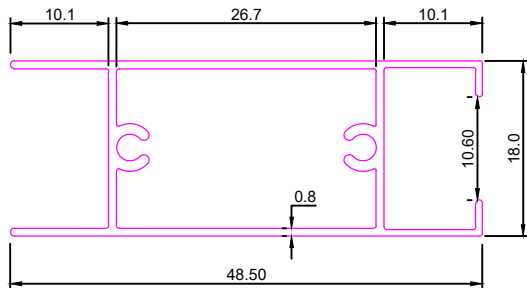



18X50 SLIDING SERIES

SEC NO. :-2706

Weight :- 1.370kg/12'

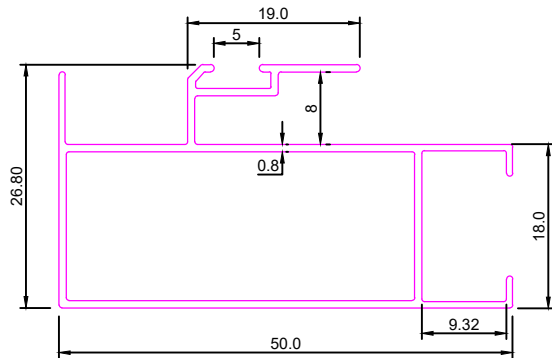

SEC NO. :-2711

Weight :- 1.435kg/12'

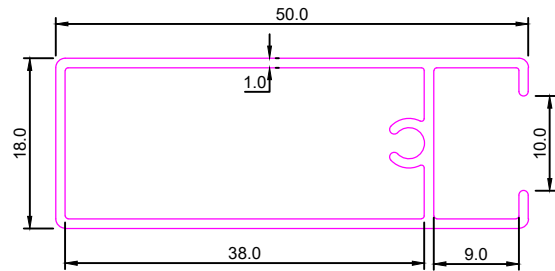

SEC NO. :-2716

Weight :- 1.700kg/12'

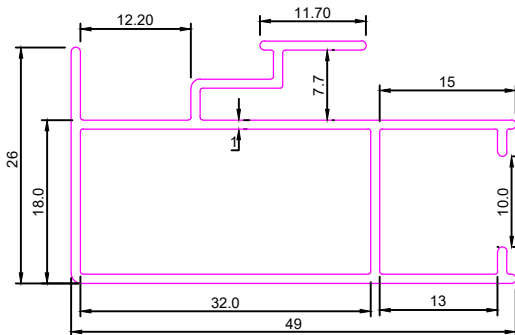

SEC NO. :-2721

Weight :- 1.335kg/12'

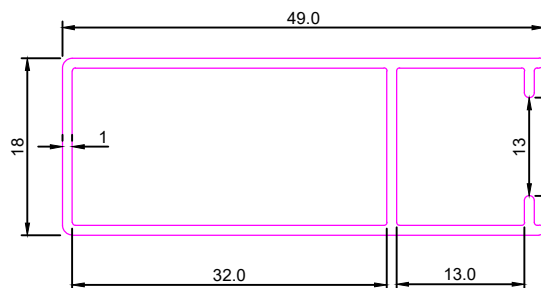

SEC NO. :-2726

Weight :- 1.200kg/12'

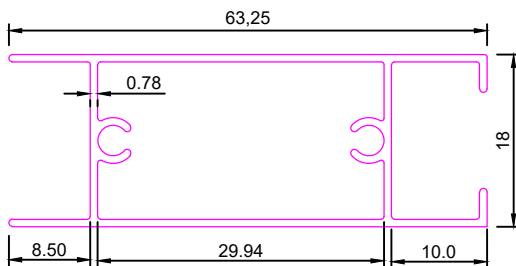

SEC NO. :-2731

Weight :- 1.520kg/12'

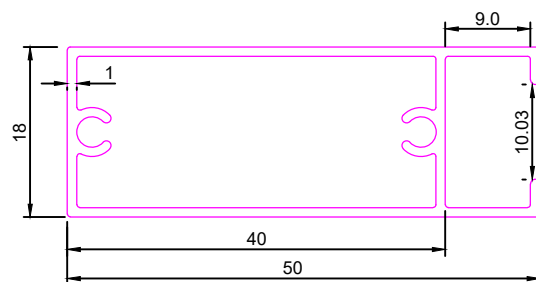



18X60 SLIDING SERIES

SEC NO. :-2751

Weight :- 2.555kg/12'

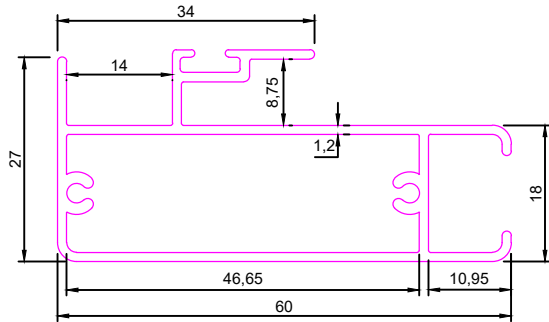

SEC NO. :-2761

Weight :- 2.120kg/12'

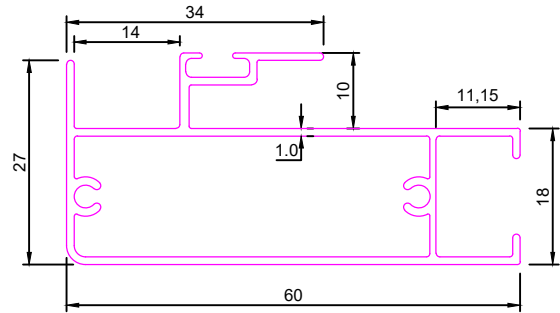

SEC NO. :-2766

Weight :- 2.050kg/12'

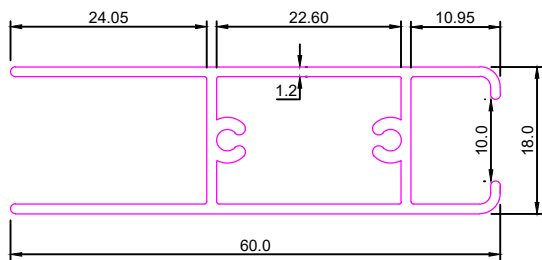

SEC NO. :-2771

Weight :- 1.910kg/12'

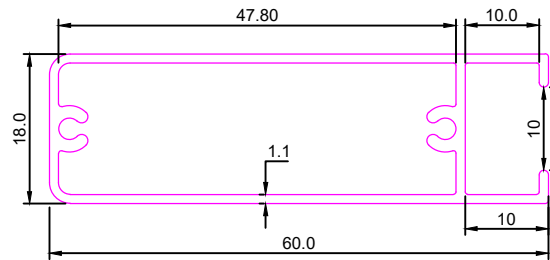

SEC NO. :-2776

Weight :- 1.690kg/12'

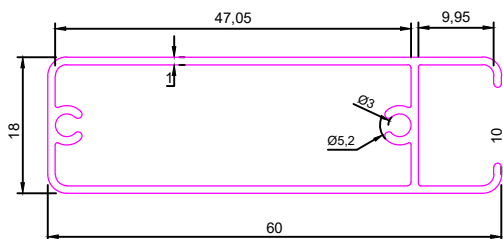

SEC NO. :-2781

Weight :- 1.725kg/12'

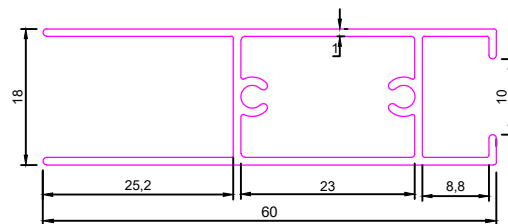



20mm SERIES

SEC NO. :-2801

Weight :- 1.255kg/12'

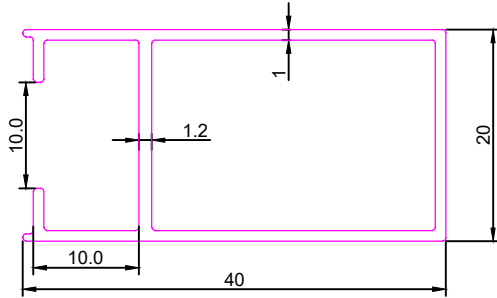

SEC NO. :-2802

Weight :- 1.425kg/12'

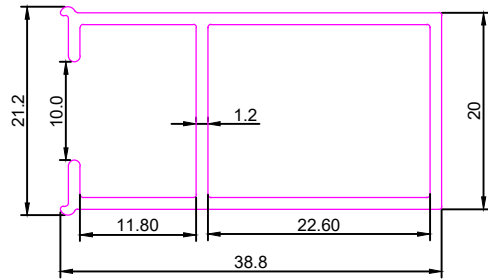

SEC NO. :-2803

Weight :- 1.410kg/12'

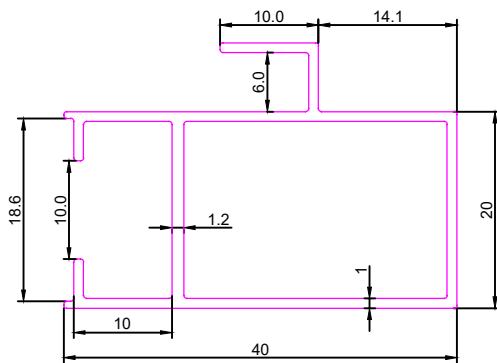

SEC NO. :-2804

Weight :- 1.700kg/12'

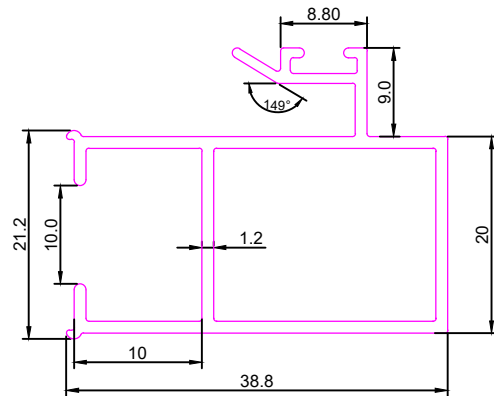

SEC NO. :-2805

Weight :- 2.330kg/12'

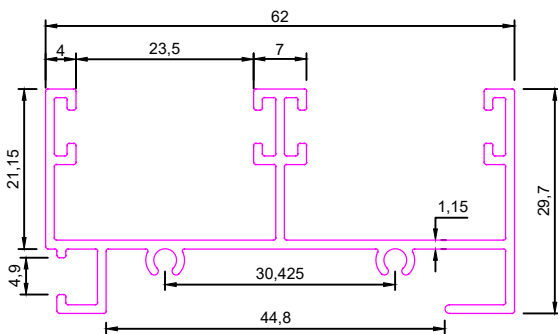

SEC NO. :-2806

Weight :- 2.625kg/12'

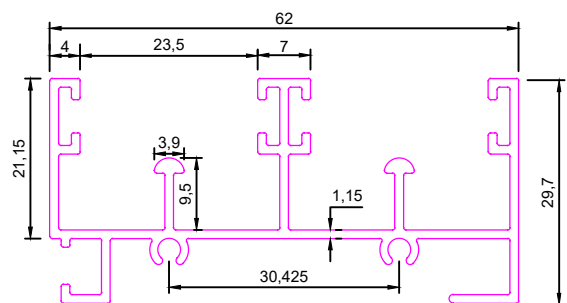



20mm SERIES

SEC NO. :-2807

Weight :- 3.195kg/12'

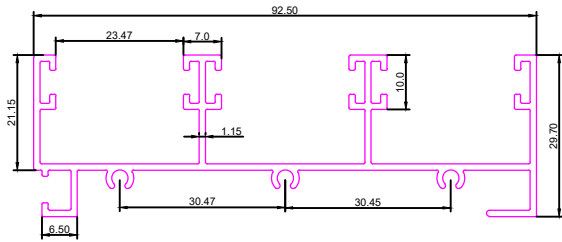

SEC NO. :-2808

Weight :- 3.635kg/12'

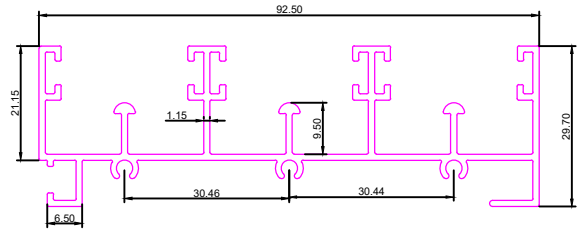

SEC NO. :-2809

Weight :- 1.400kg/12'

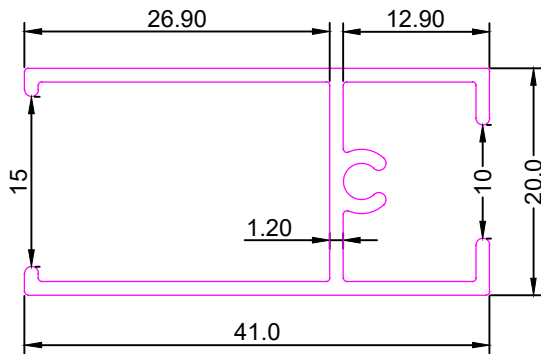



25mm (1") SERIES

1" HANDLE

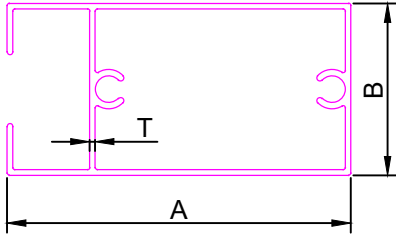

SEC. NO.	A	B	T	WT. kg./mtr	Weight KG/12'
2825	50.00	25.00	0.85	0.420	1.500-1.700
2826	50.00	25.00	1.20	0.593	2.100-2.300
2827	50.00	25.00	1.30	0.617	2.260-2.400
2828	50.00	25.00	1.40	0.655	2.400-2.600
2829	50.00	25.00	1.50	0.717	2.600-2.800

1" MATTING

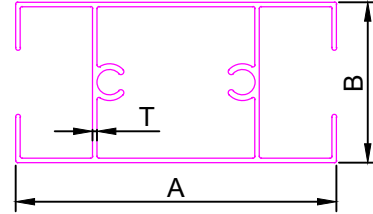

SEC. NO.	A	B	T	WT. kg./mtr	Weight KG/12'
2836	50.00	25.00	0.85	0.437	1.600-1.800
2837	50.00	25.00	0.95	0.510	1.800-2.100
2838	50.00	25.00	1.40	0.683	2.500-2.700
2839	52.00	18.00	0.78	0.339	1.200-1.500

SEC NO. :-5121

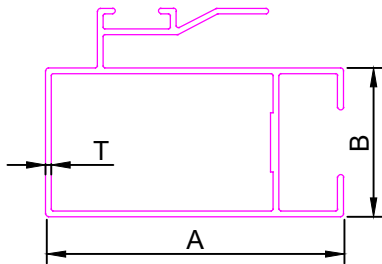

SEC. NO.	A	B	T	WT. kg./mtr	Weight KG/12'
2845	50.00	25.00	1.20	0.633	2.300-2.400
2846	50.00	25.00	1.30	0.683	2.400-2.600
2847	50.00	25.00	1.50	0.788	2.800-3.100

SEC NO. :-2851

Weight :- 1.540kg/12'

1" TOP BOTTOM

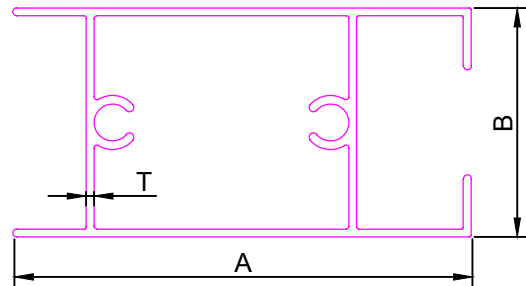

SEC NO. :-2856

Weight :- 1.500kg/12'

1" SINGLE LEG TOP BOTTOM

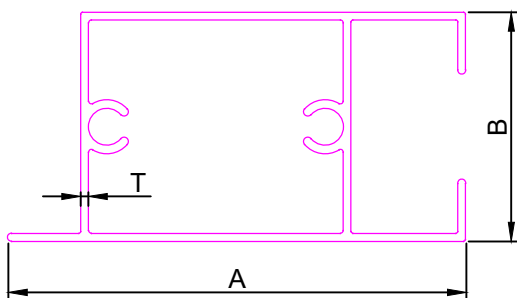

SEC NO. :-2861

Weight :- 6.470kg/12'

1" 3 TRACK BOTTOM HOLLOW

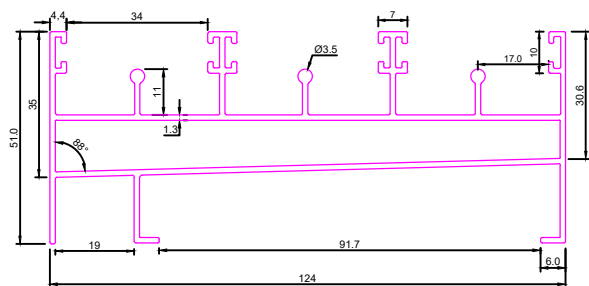



25mm (1") SERIES

1" 2 TRACK TOP

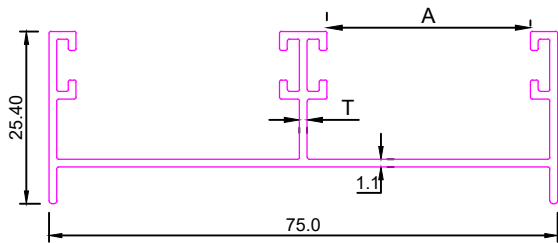

SECTION NO.	A	T	WT. RANGE KGS/12'
2871	29.25	1.10	2.000-2.200
2872	29.10	1.35	2.200-2.400
2873	29.15	1.40	2.500-2.800

1" 2 TRACK BOTTOM

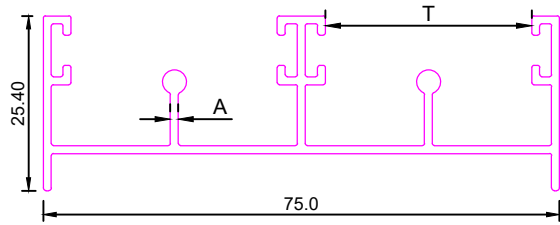

SECTION NO.	A	T	WT. RANGE KGS/12'
2876	29.35	1.10	2.200-2.400
2877	29.00	1.30	2.400-2.600
2878	29.00	1.35	2.700-3.000

1" 3 TRACK TOP

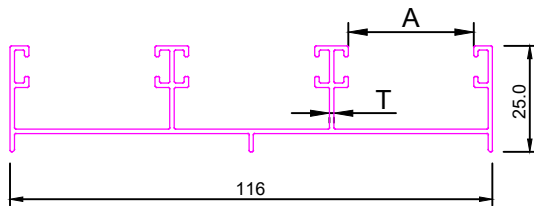

SECTION NO.	A	T	WT. RANGE KGS/12'
2881	30.20	1.25	3.200-3.400
2882	29.60	1.60	4.000-4.200
2883	29.20	1.95	4.400-4.600

SEC NO. :-5176

1" 3 TRACK BOTTOM

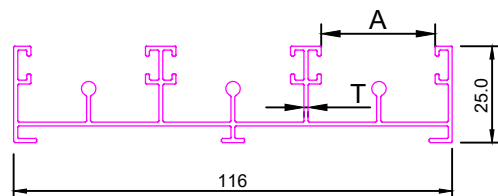

SECTION NO.	A	T	WT. RANGE KGS/12'
2886	30.55	1.15	3.200-3.400
2887	29.85	1.35	4.000-4.200
2888	29.50	1.62	4.400-4.600

SEC NO. :-2891

1" 4 TRACK TOP

Weight :- 3.930kg/12'

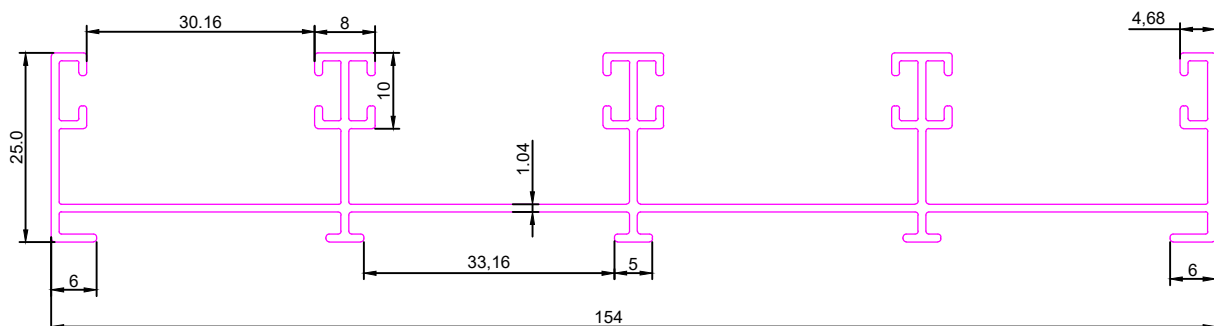



25mm (1") SERIES

SEC NO. :-2896

Weight :- 4.565kg/12'

1" 4 TRACK BOTTOM

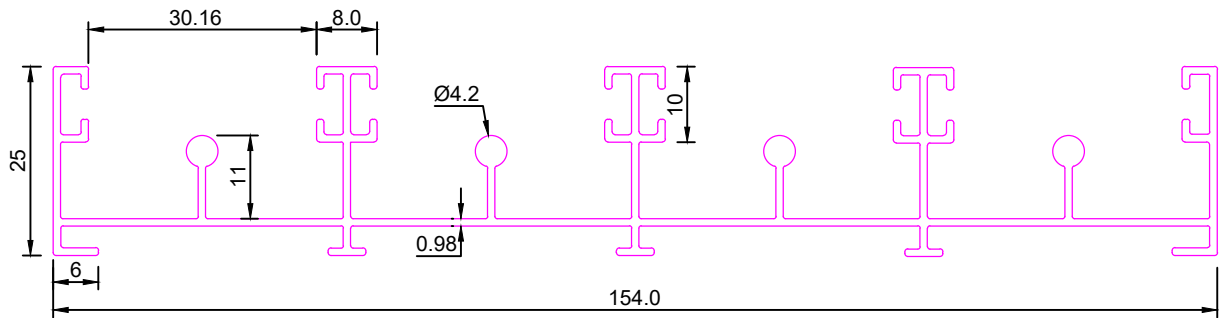

SEC NO. :-2901 (25mm)1"

Weight :- 6.400kg/12'

2 TRACK BOTTOM HOLLOW

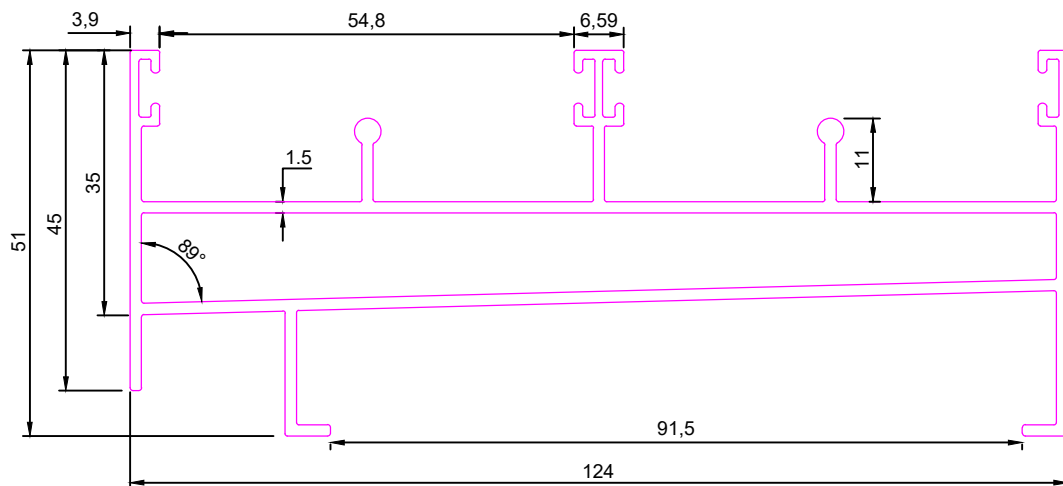



25mm (1") SERIES

SEC. NO:-3001

Weight :- 2.385kg/12'

65 X 25 HANDLE

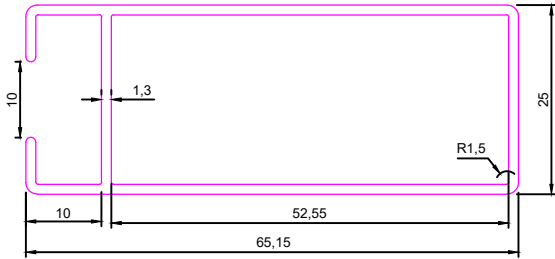

SEC. NO:-3005

Weight :- 3.025kg/12'

65 X 25 INTERLOCK

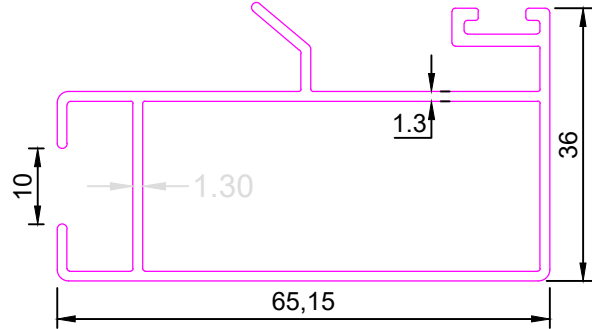

SEC. NO:-3009

Weight :- 1.935kg/12'

60 X 25 HANDLE

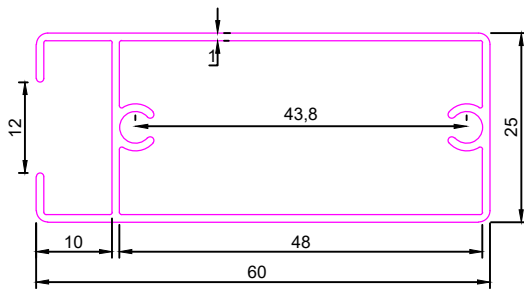

SEC. NO:-3009/1

Weight :- 2.180kg/12'

75 X 25 MATTING

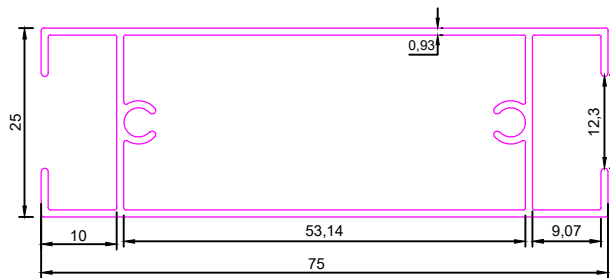

SEC. NO:-3011/1

Weight :- 2.242kg/12'

75 X 25 HANDLE

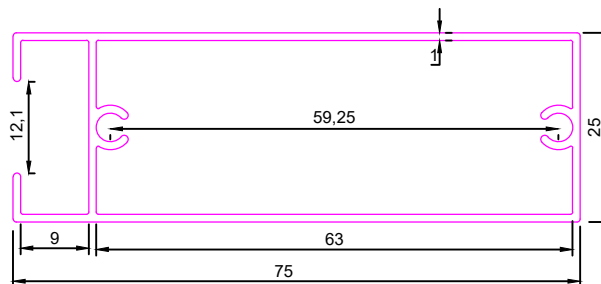



30mm SERIES

SEC NO. :-2901

Weight :- 2.675kg/12'

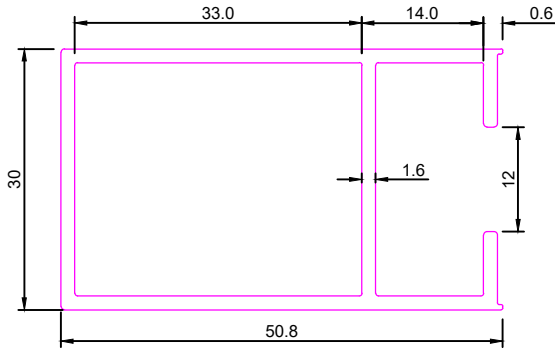

SEC NO. :-2911

Weight :-2.765kg/12'

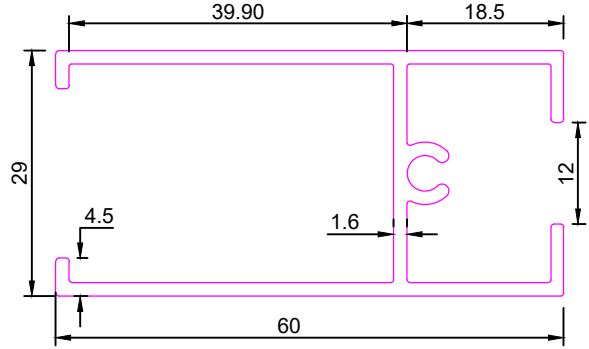

SEC NO. :-2916

Weight :- 3.290kg/12'

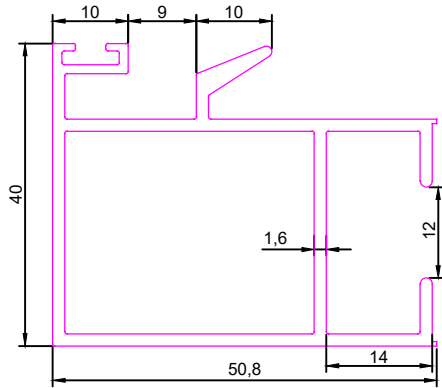

SEC NO. :-2921

Weight :- 5.420kg/12'

2 TRACK BOTTOM HOLLOW

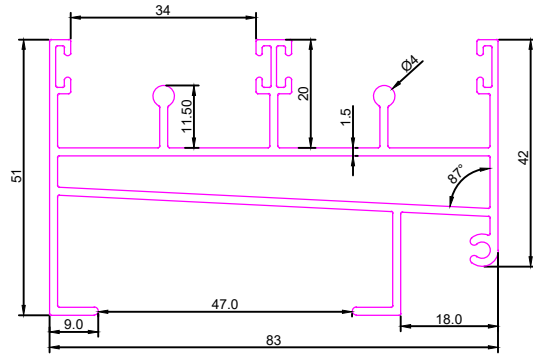

SEC NO. :-2951

Weight :- 7.325kg/12'

30mm 3 TRACK BOTTOM HOLLOW

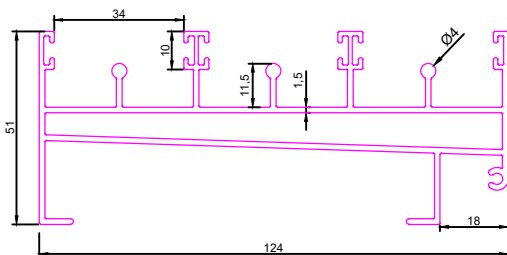

SEC NO. :-2956

Weight :- 3.200kg/12'

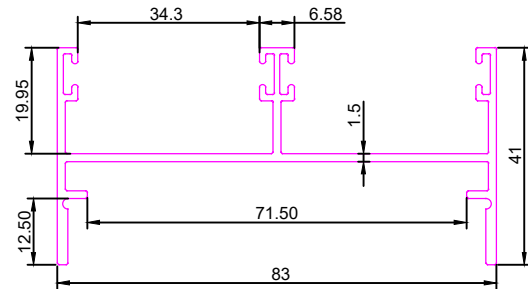



30mm SERIES

SEC. NO:-2961

Weight :- 3.690kg/12'

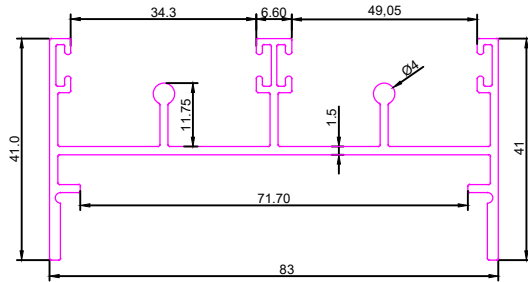

SEC. NO:-2966

Weight :- 4.275kg/12'

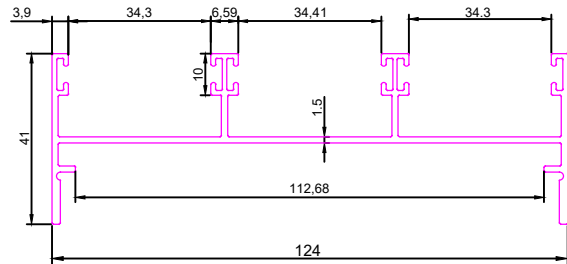

SEC. NO:-2971

Weight :- 5.380kg/12'

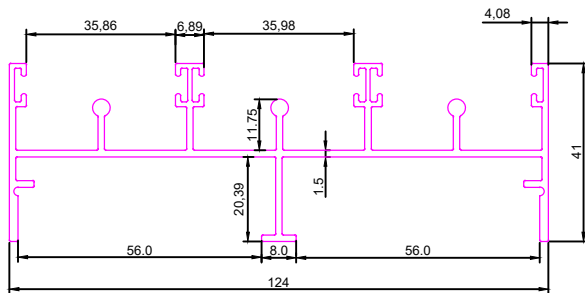

SEC. NO:-3007

Weight :- 2.600kg/12'

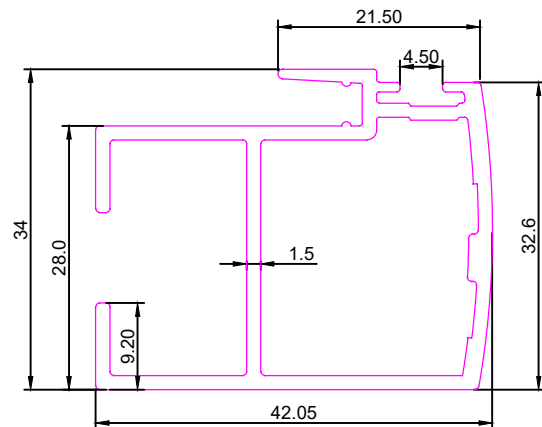

SEC. NO:-3011

Weight :- 3.550kg/12'

65 X 30 INTERLOCK

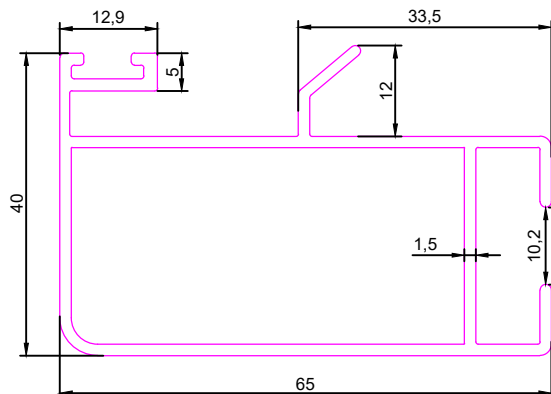

SEC. NO:-3015

Weight :- 2.910kg/12'

65 X 30 HANDLE

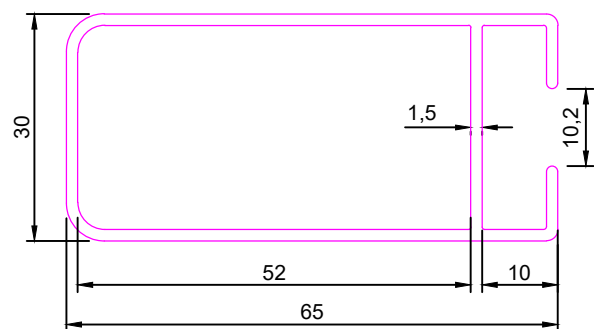



30mm SERIES

SEC. NO:- 3841

Weight :- 1.460kg/12'

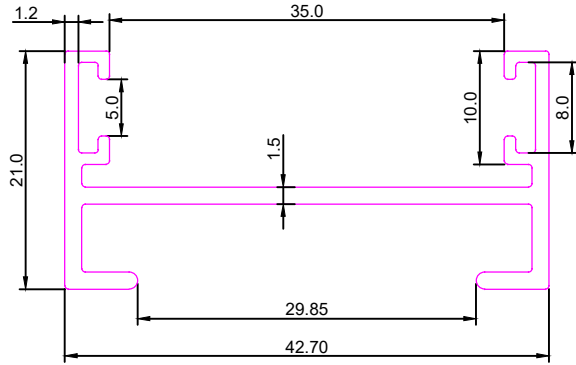

SEC. NO:- 3843

Weight :- 2.875kg/12'

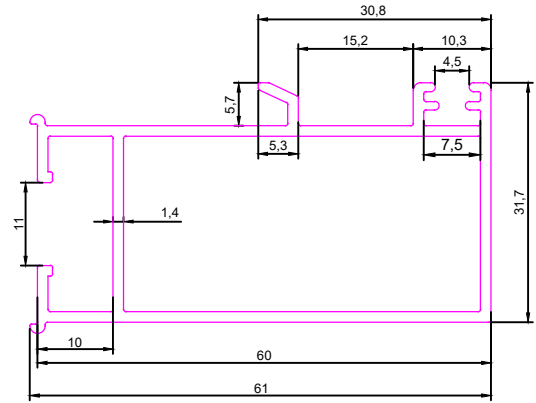

SEC. NO:- 3845

Weight :-2.885kg/12'

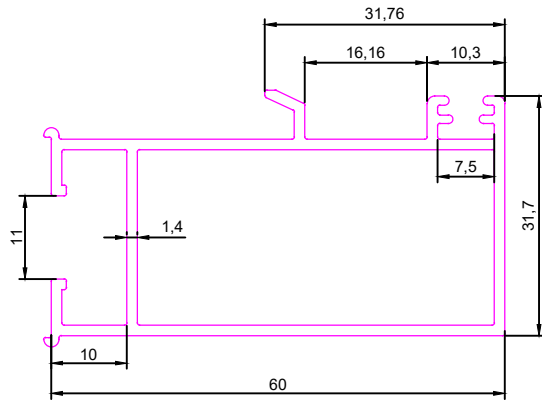



50mm SERIES

SEC No. 7046

Weight-4.150kg/12'

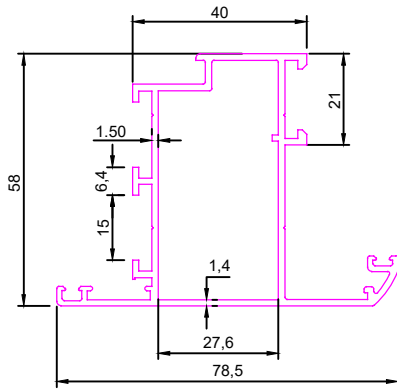

SEC No. 7047

Weight-4.700kg/12'

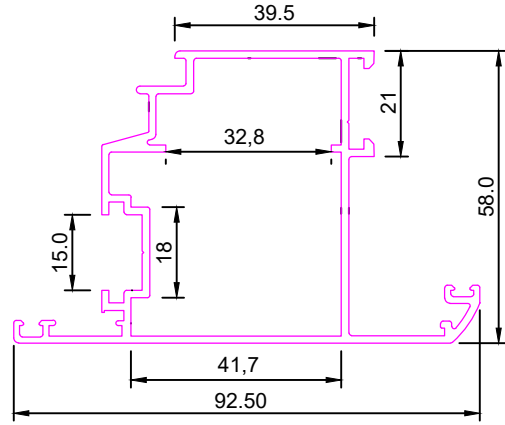



SLIDING

SEC. NO:- 3805

Weight :-2.500kg/12'

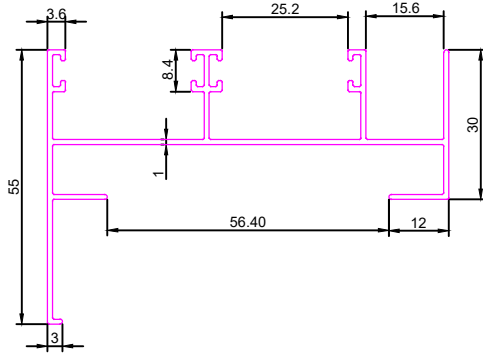

SEC. NO:- 3807

Weight :- 2.830kg/12'

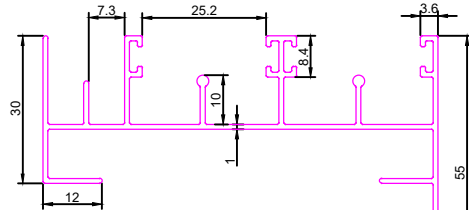

SEC. NO:- 3809

Weight :- 1.890kg/12'

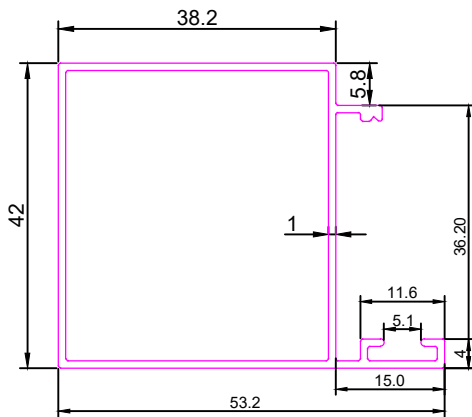

SEC. NO:- 3811

Weight :- 0.790kg/12'

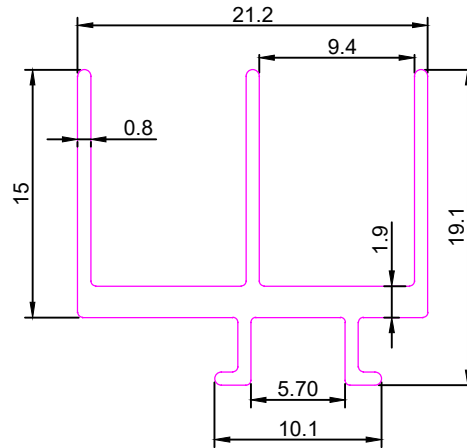

SEC. NO:- 3813

Weight :- 0.600kg/12'

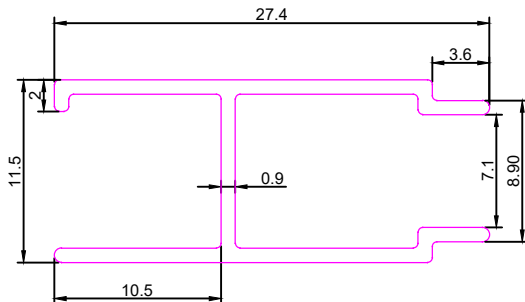

SEC. NO:- 3815

Weight :- 0.570kg/12'

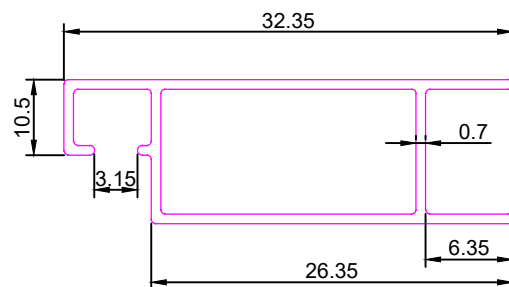



SLIDING

SEC. NO:- 3817

Weight :- 1.290kg/12'

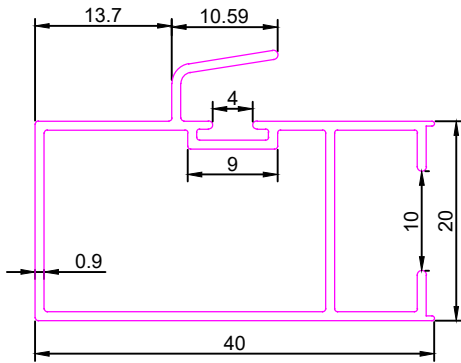

SEC. NO:- 3819

Weight :- 0.970kg/12'

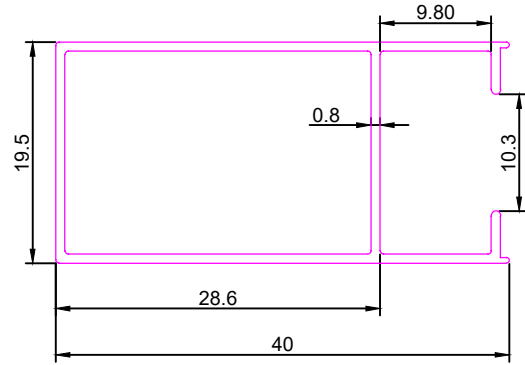

SEC. NO:- 3821

Weight :- 1.140kg/12'

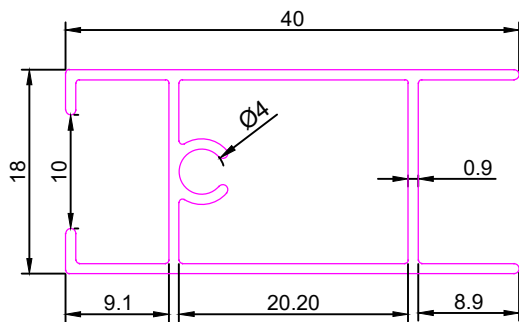

SEC. NO:- 3823

Weight :- 1.360kg/12'

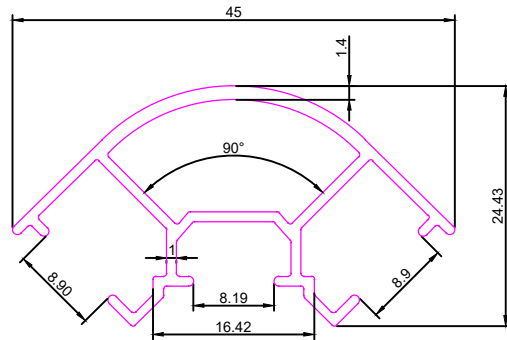

SEC. NO:- 3825

Weight :- 0.575kg/12'

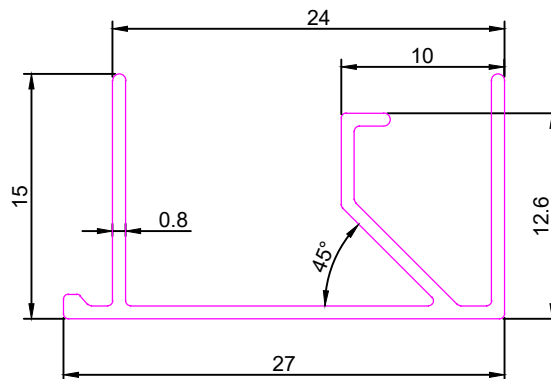



SLIDING

SEC No. 7100

Weight :- 2.340kg/12'

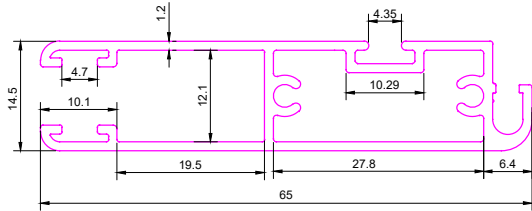

SEC No. 7101

Weight :- 2.890kg/12'

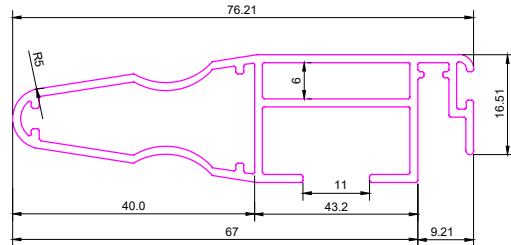

SEC No. 7201

Weight :- 2.035kg/12'

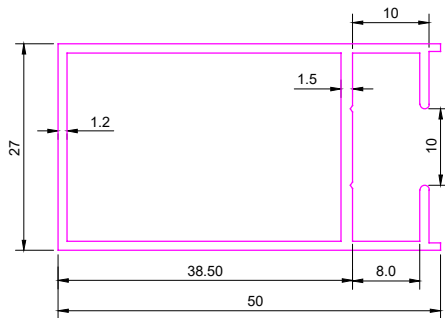

SEC No. 7202

Weight :- 2.300kg/12'

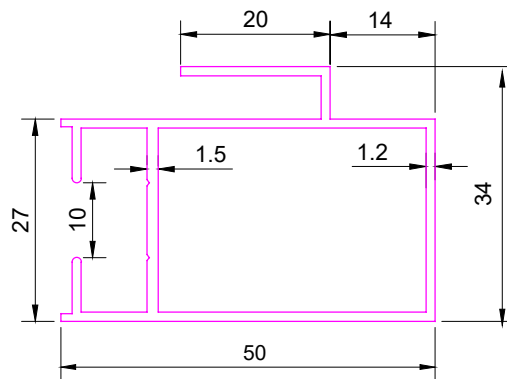

SEC No. 7232

Weight :- 2.450kg/12'

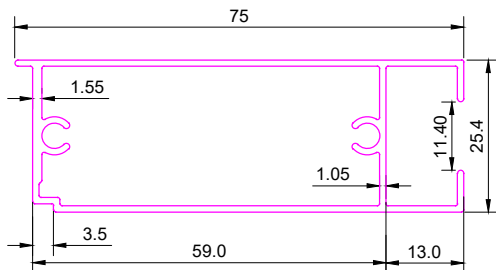

SEC No. 7262

Weight :- 1.750kg/12'

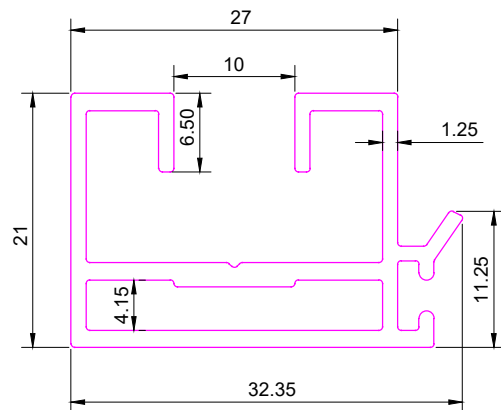



SLIDING

SEC No. 7263

Weight :- 2.825kg/12'

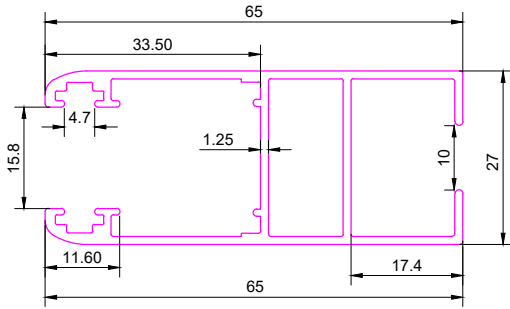

SEC No. 7321

Weight :- 1.960kg/12'

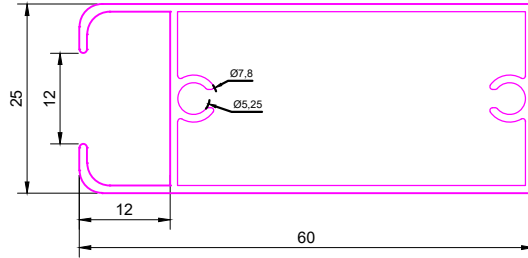

SEC No. 7382

Weight :- 2.125kg/12'

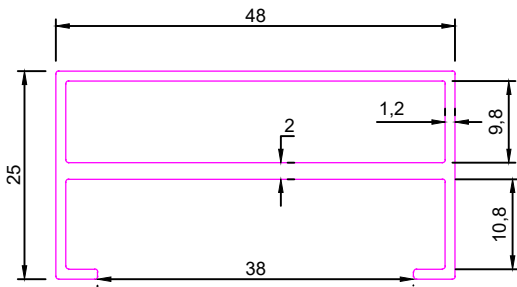

SEC No. 7406

Weight :- 4.670kg/12'

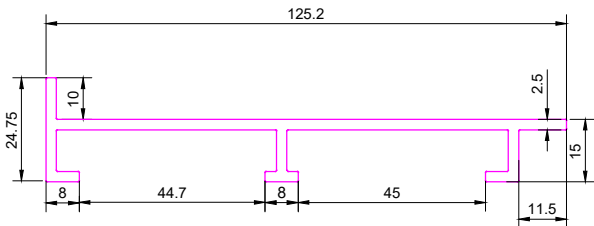

SEC No. 7407

Weight :- 1.400kg/12'

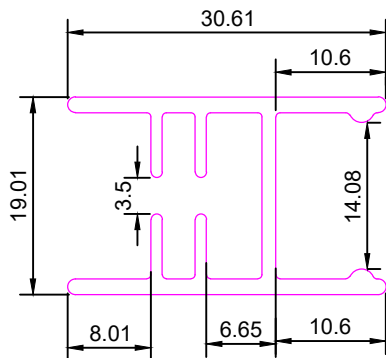

SEC No. 7408

Weight :- 6.150kg/12'

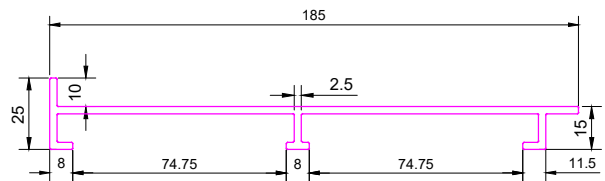



SLIDING

SEC No. 7409

Weight :- 1.810kg/12'

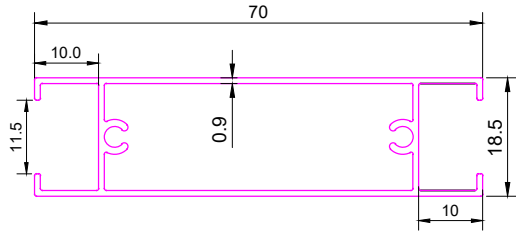

SEC No. 7410

Weight :- 1.855kg/12'

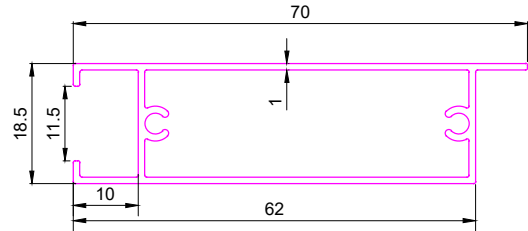

SEC No. 7411

Weight :- 1.850kg/12'

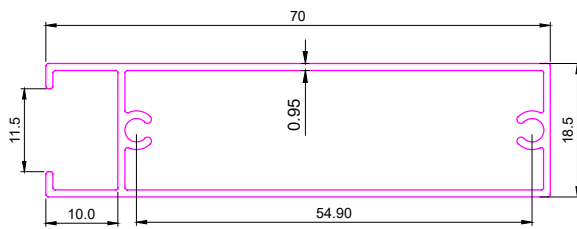

SEC No.7442

Weight :- 1.360kg/12'

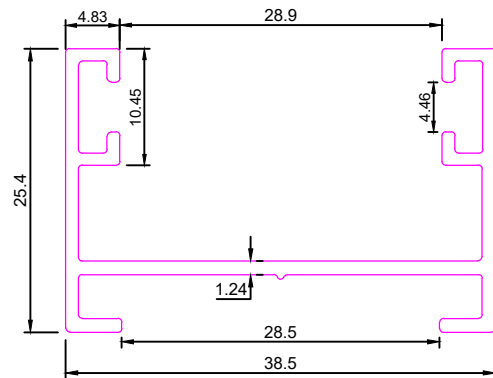

SEC No.7443

Weight :- 1.570kg/12'

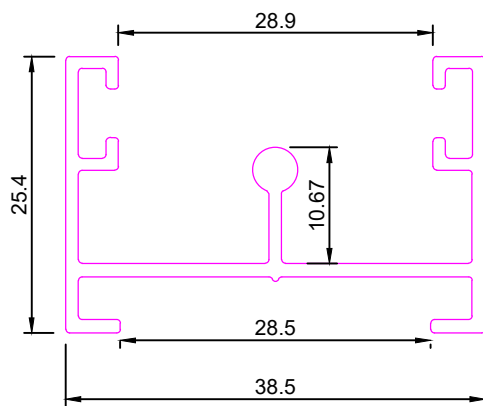

SEC No. 7501

Weight :- 8.470kg/12'

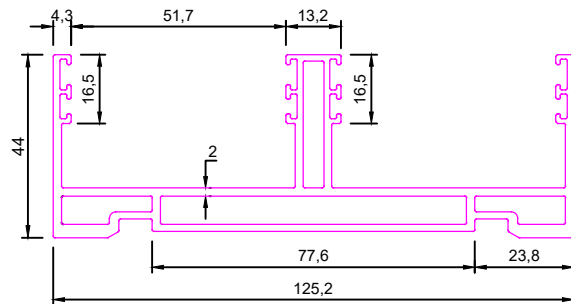



SLIDING

SEC No. 7502

Weight :-10.100kg/12'

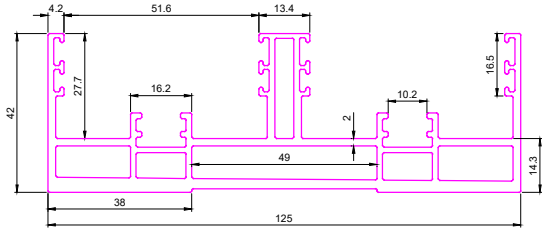

SEC No. 7503

Weight :- 8.570kg/12'

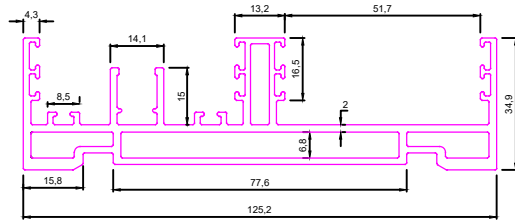

SEC No. 7504

Weight :-5.400kg/12'

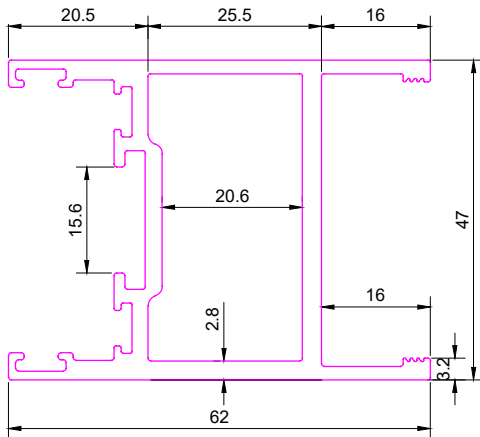

SEC No. 7505

Weight :-5.800kg/12'

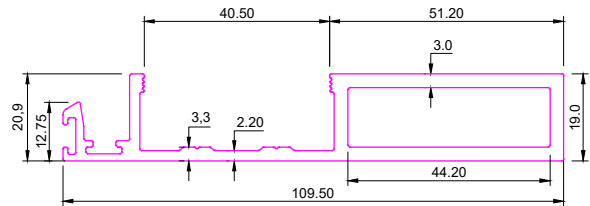

SEC No. 7506

Weight :-5.600kg/12'

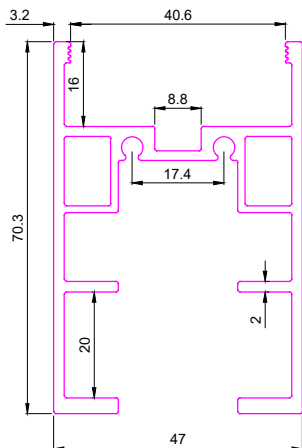

SEC No. 7507

Weight :-0.565kg/12'

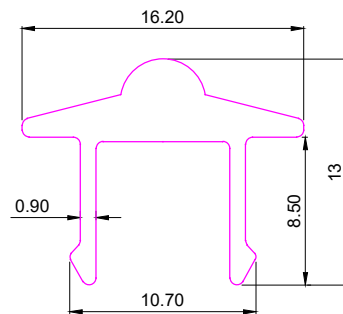



SLIDING

SEC No. 7508

Weight :-1.000kg/12'

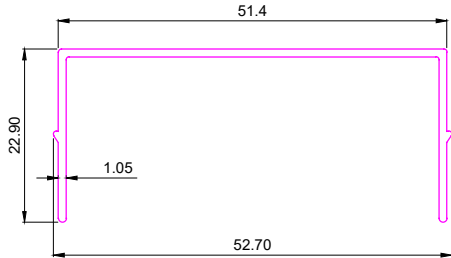

SEC No. 7509

Weight :- 2.900kg/12'

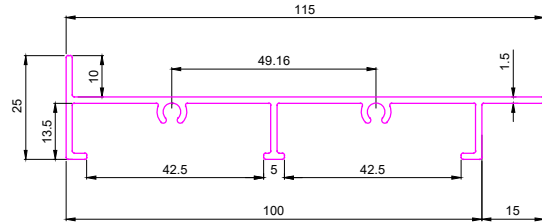



SLIDING WINDOW

SEC No. 2451

Weight :- 2.780kg/12'

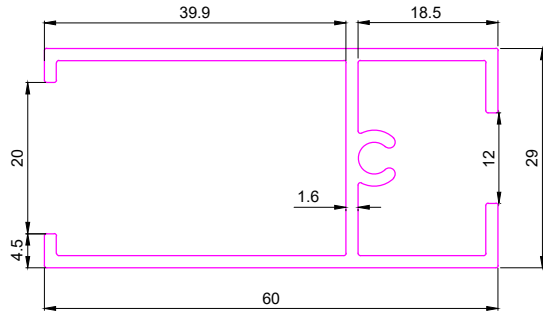

SEC No. 2461

Weight :- 2.670kg/12'

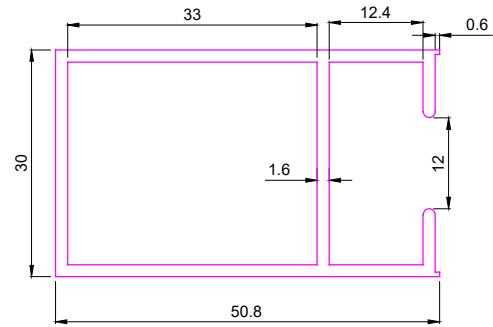

SEC No. 2471

Weight :-3.290kg/12'

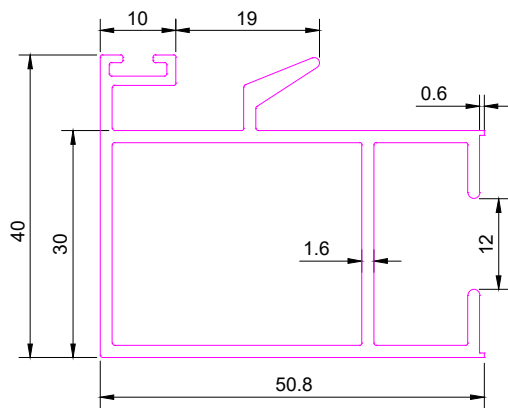

SEC No. 2591

Weight :- 4.100-4.600kg/12'

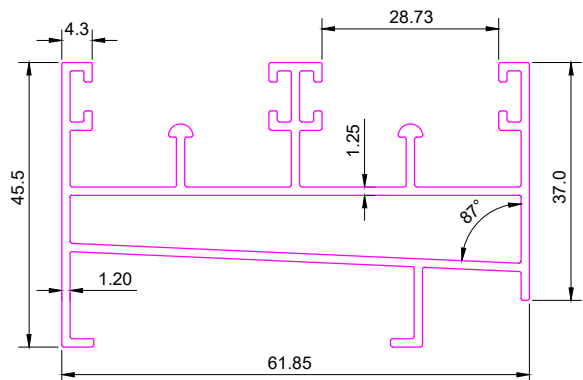

SEC No. 2601

Weight :-4.200kg/12'

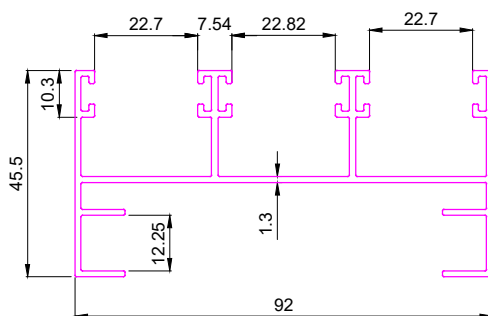

SEC No. 2602

Weight :-4.00-4.500kg/12'

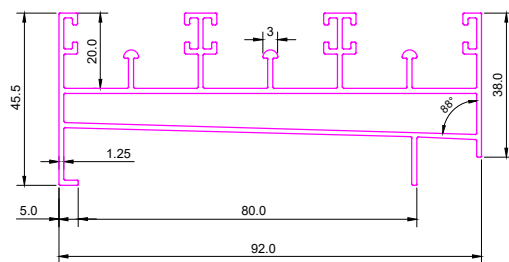



SLIDING WINDOW

SEC. NO. 3011/3

Weight :-1.900-2.200kg/12'

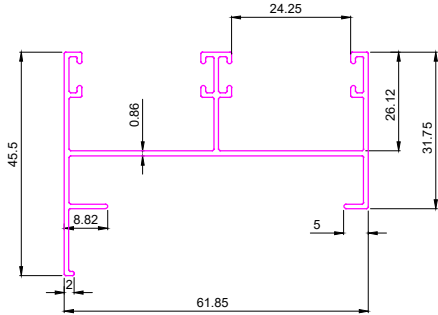

SEC. NO. 3021

Weight :- 2.200-2.600kg/12'

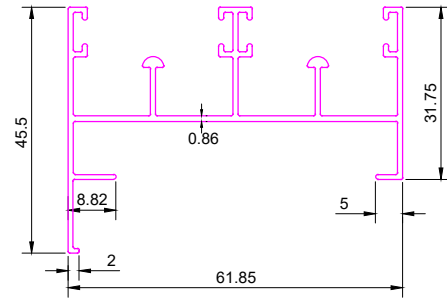

SEC. NO. 7152

Weight :- 2.800kg/12'

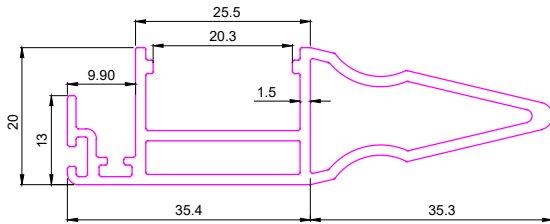

SEC No. 7153

Weight :- 2.600kg/12'

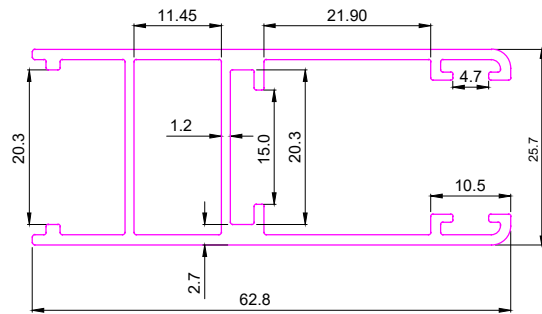

SEC No. 7154

Weight :-1.470kg/12'

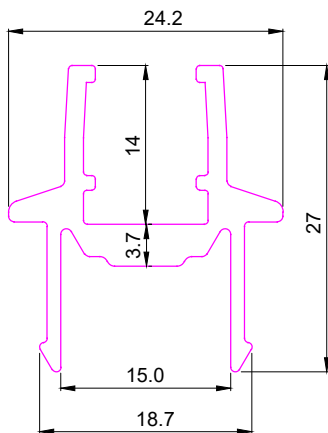

SEC No. 7155

Weight :-4.050kg/12'

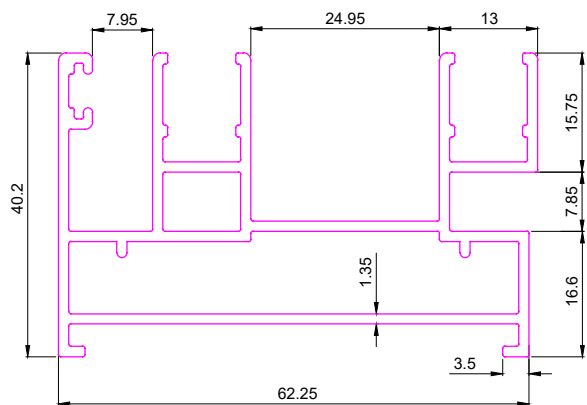



SLIDING WINDOW

SEC No. 7156

Weight :-5.000kg/12'

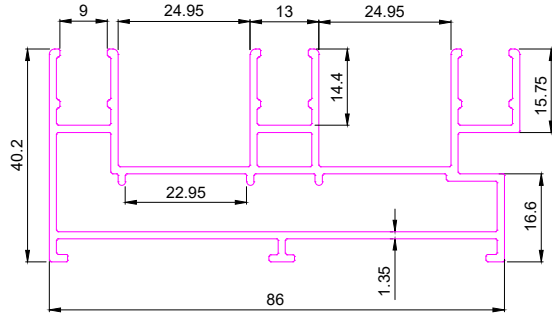

SEC No. 7157

Weight :-0.600kg/12'

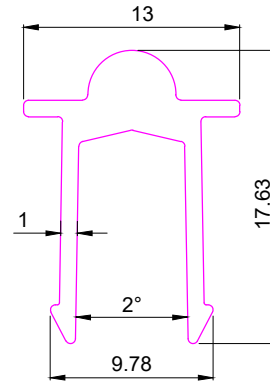

SEC No. 7158

Weight :-3.700kg/12'

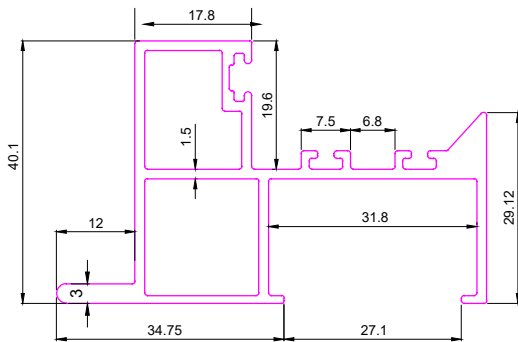

SEC No. 7385

Weight :-1.940kg/12'

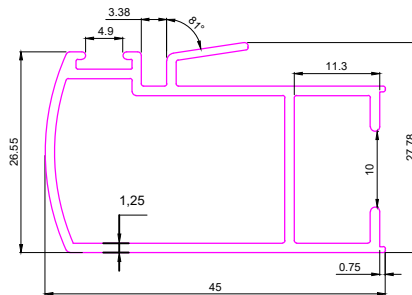

SEC No. 7387

Weight :-3.700kg/12'

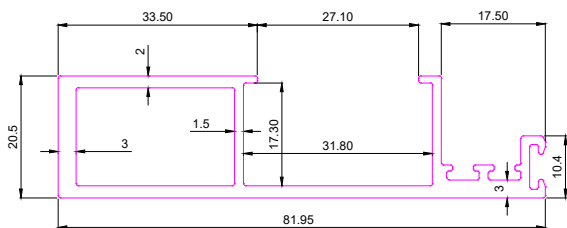

SEC No. 7524

Weight :-3.340kg/12'

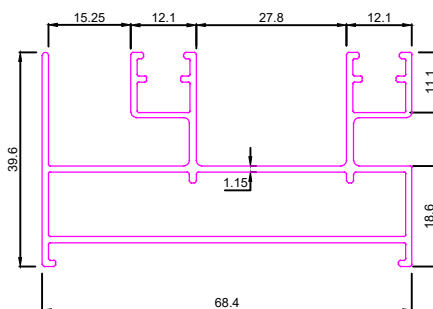



SLIDING WINDOW

SEC No. 7525

Weight :- 2.570kg/12'

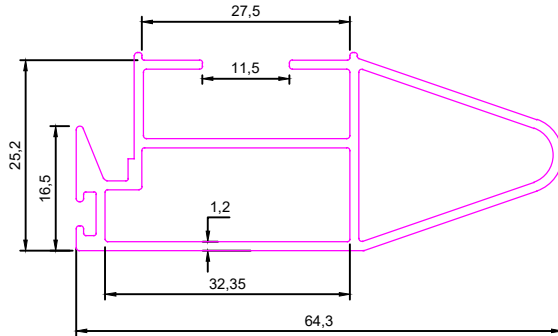

SEC No. 7526

Weight :- 1.865kg/12'

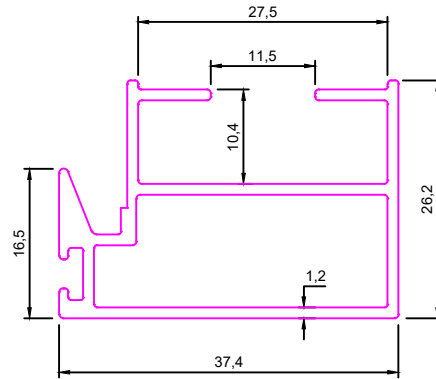

SEC No. 7527

Weight :- 4.445kg/12'

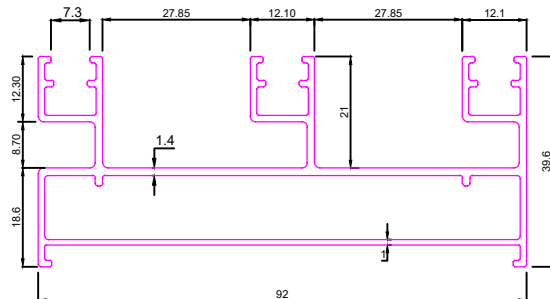

SEC No. 7704

Weight :- 1.950kg/12'

18x60 Sliding Series

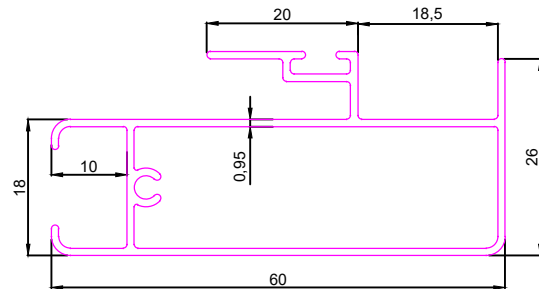

SEC No. 7708

Weight:-4.850Kg/12'

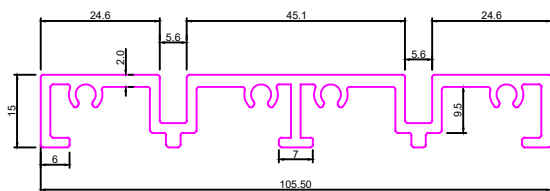

SEC No. 7709

Weight:-3.735Kg/12'

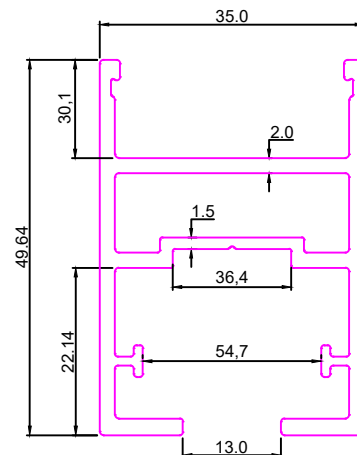



SLIDING WINDOW

SEC No. 7795

Weight:-4.935Kg/12'

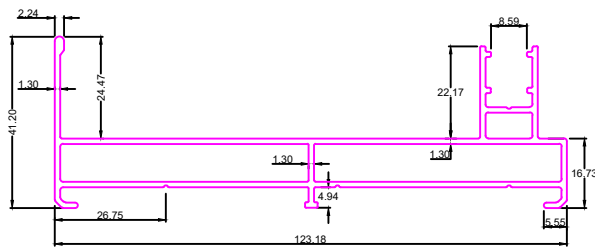

SEC No. 7796

Weight:-4.935Kg/12'

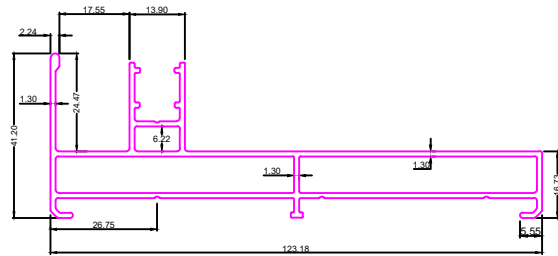

SEC No. 7797

Weight:-7.130Kg/12'

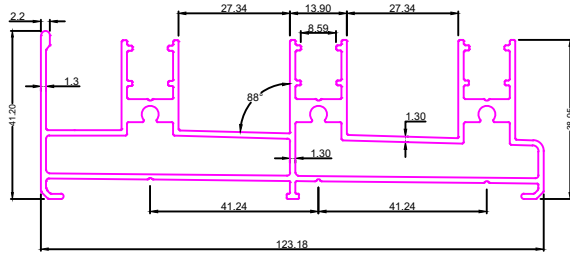

SEC No. 7798

Weight:-4.950Kg/12'

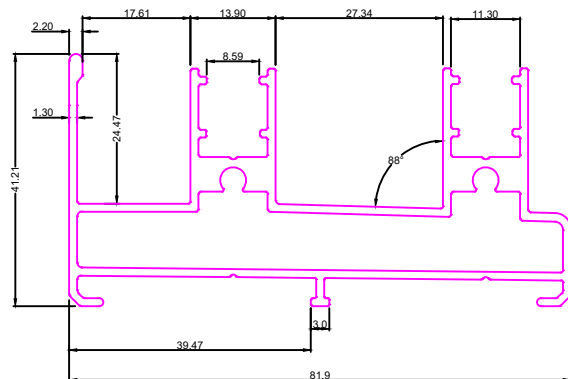

SEC No. 7799

Weight:-3.675Kg/12'

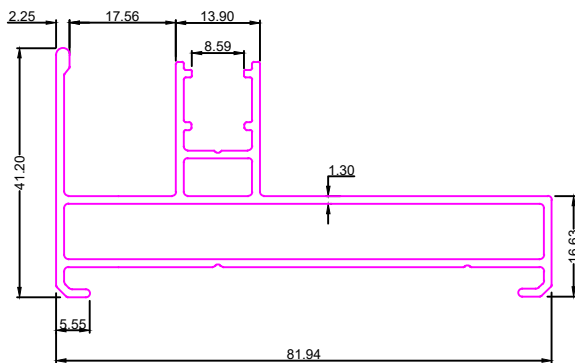

SEC No. 7800

Weight:-3.650Kg/12'

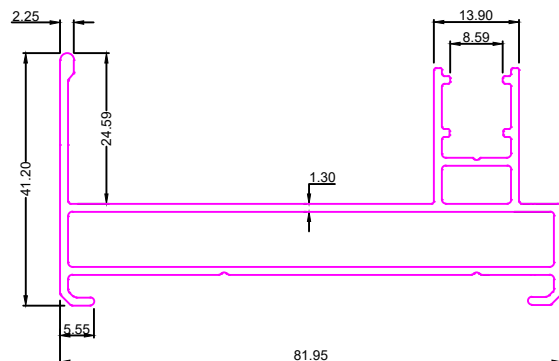



SLIDING WINDOW

SEC No. 7801

Weight:-2.325Kg/12'

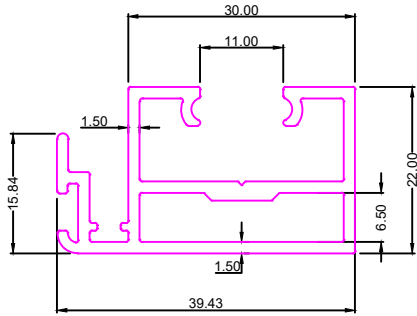

SEC No. 7802

Weight:-3.055Kg/12'

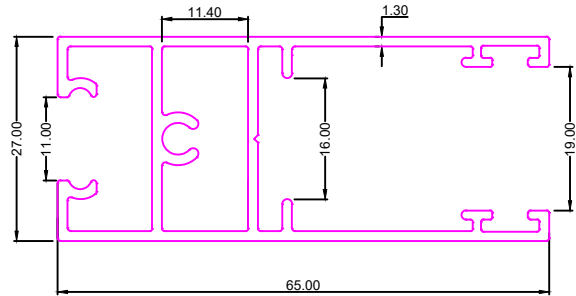

SEC No. 7803

Weight:-3.260Kg/12'

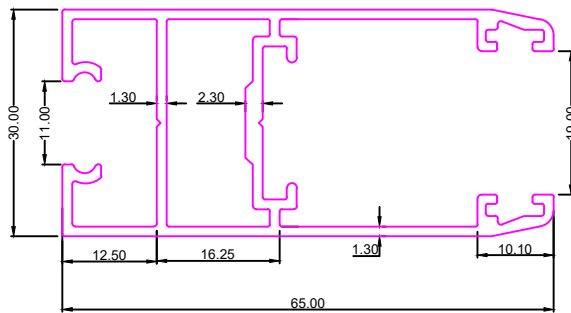

SEC No. 7804

Weight:-0.420Kg/12'

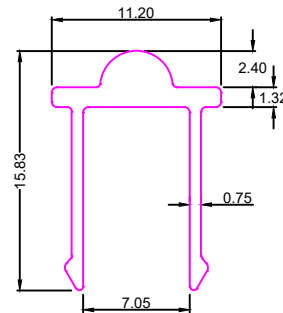

SEC No. 7805

Weight:-0.330Kg/12'

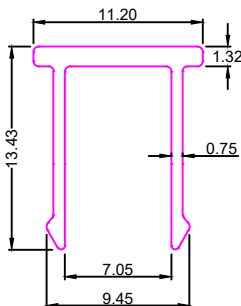

SEC No. 7806

Weight:-2.560Kg/12'

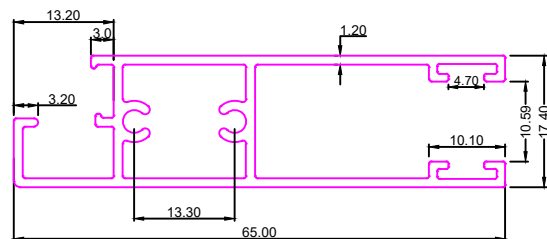



SLIDING WINDOW

SEC No. 7807

Weight:-0.332Kg/12'

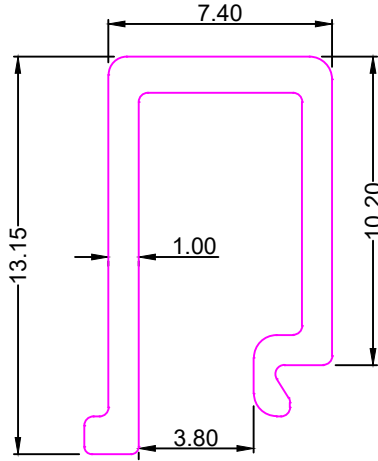

SEC No. 7808

Weight:-0.960Kg/12'

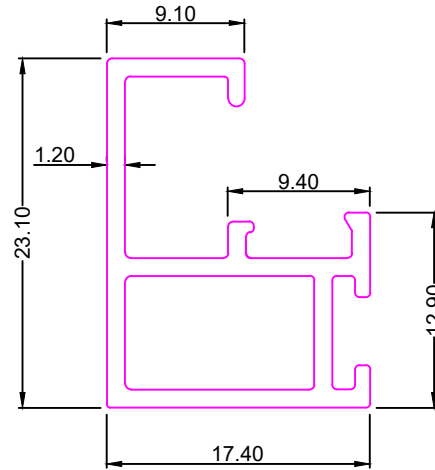

SEC No. 7809

Weight:-4.285Kg/12'

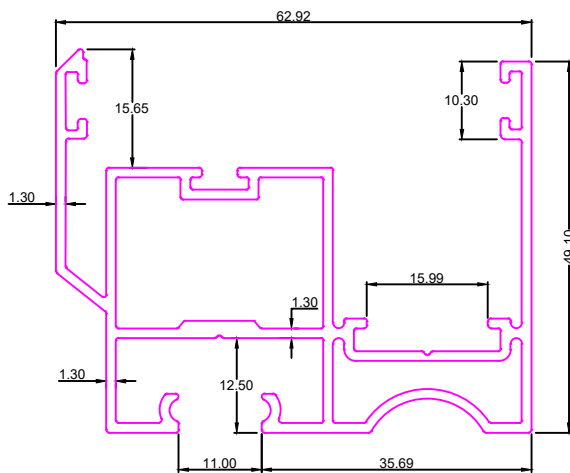

SEC No. 7810

Weight:-3.300Kg/12'

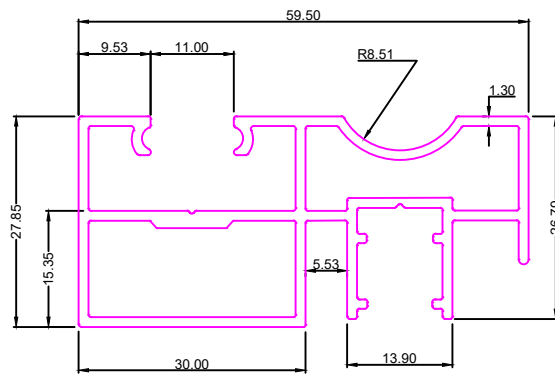

SEC No. 7811

Weight:-3.700Kg/12'

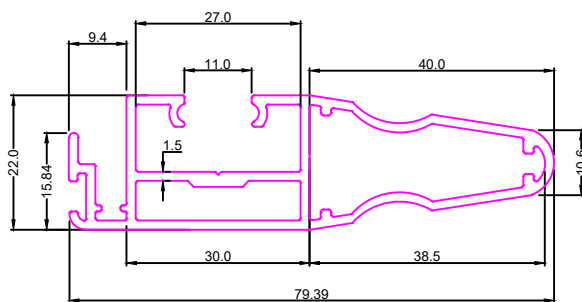

SEC No. 7820

Weight:-1.925Kg/12'

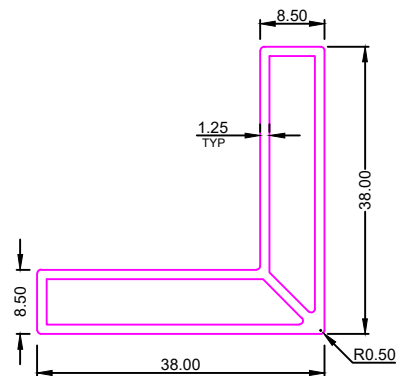



SLIDING WINDOW

SEC No. 7862

Weight:-4.350Kg/12'

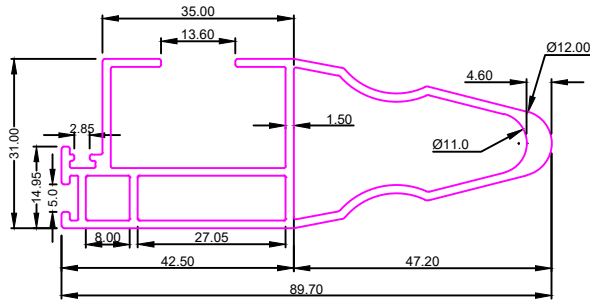

SEC No. 7863

Weight:-5.042Kg/12'

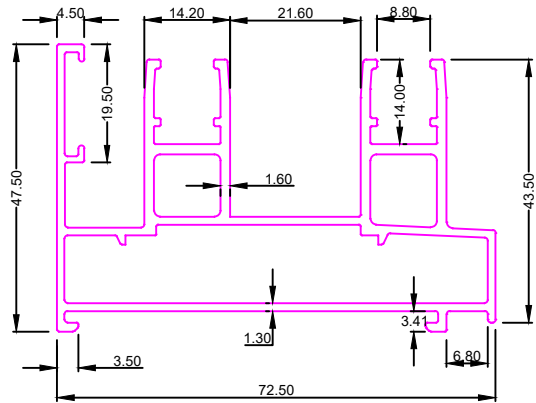

SEC No. 7864

Weight:-7.340Kg/12'

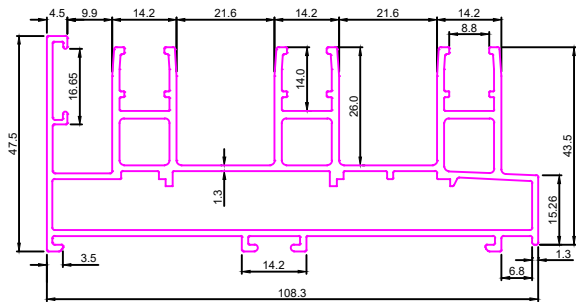

SEC No. 7865

Weight:-2.940Kg/12'

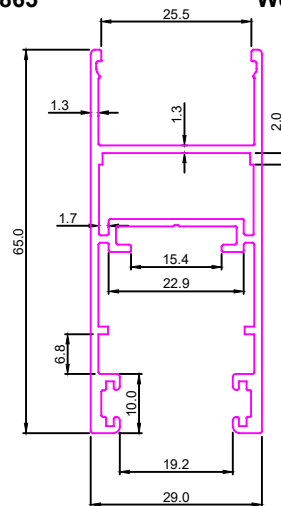

SEC No. 7866

Weight:0.775Kg/12'

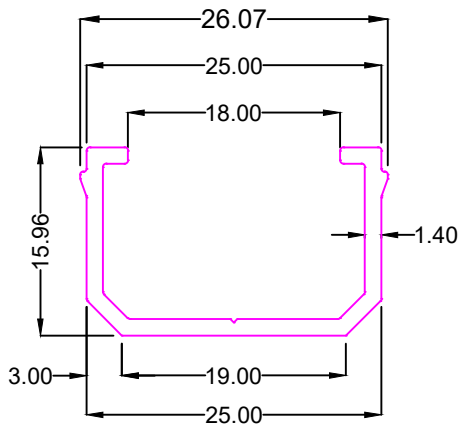

SEC No. 7867

Weight:-0.874Kg/12'

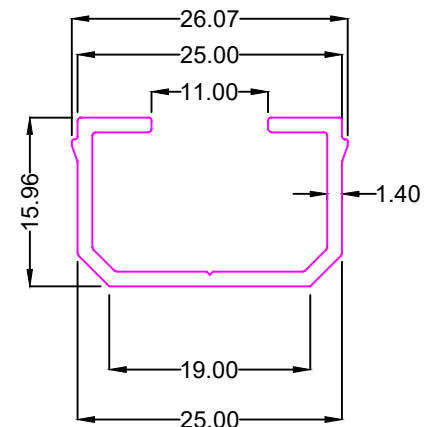



SLIDING WINDOW

SEC No. 7868

Weight:1.275Kg/12'

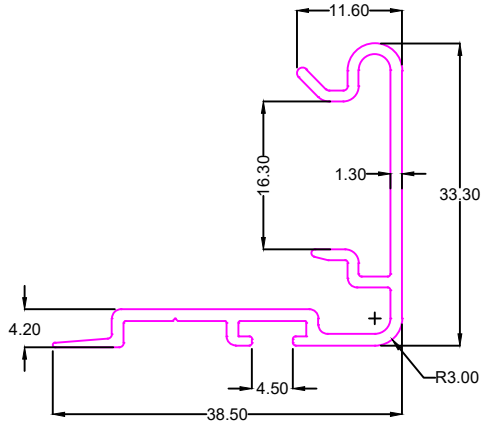

SEC No. 7889

Weight:-1.485Kg/12'

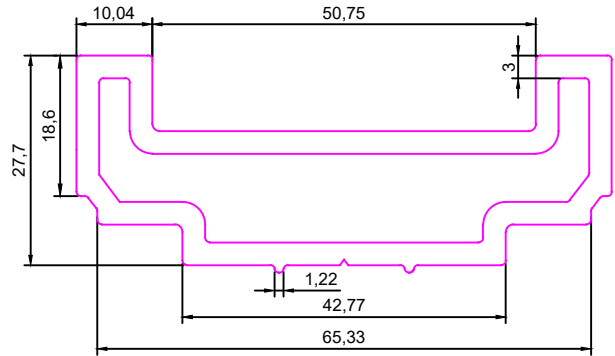

SEC No. 7916

Weight:-2.460Kg/12'

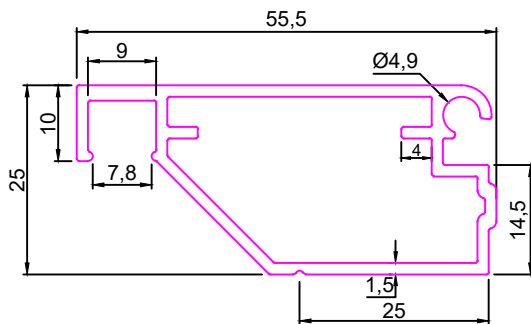

SEC No. 7917

Weight:-2.750Kg/12'

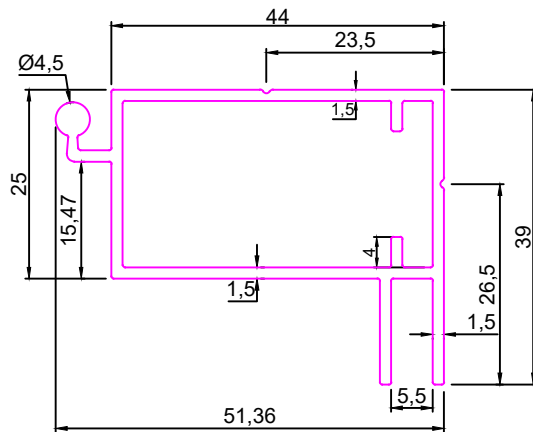

SEC No. 7918

Weight:-2.480Kg/12'

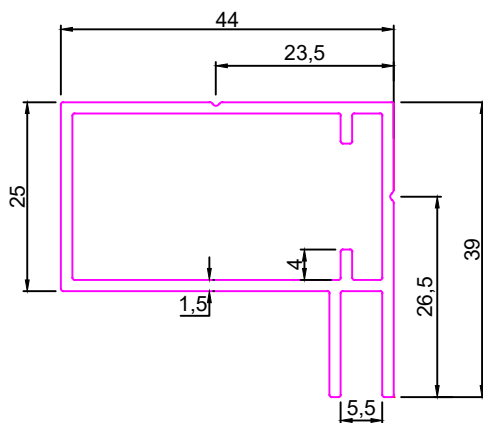

SEC No. VA7922

Weight:-2.775Kg/12'

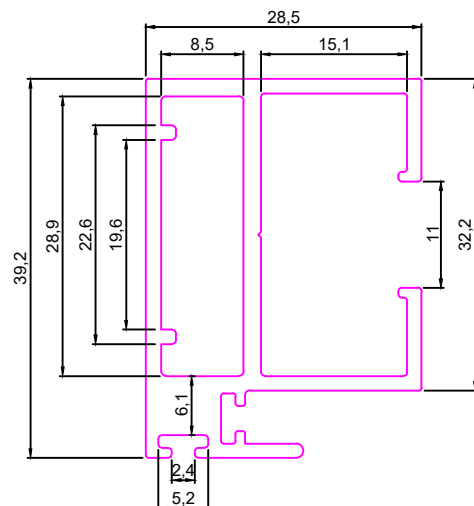



SLIDING WINDOW

SEC No. VA7923

Weight:-2.650Kg/12'

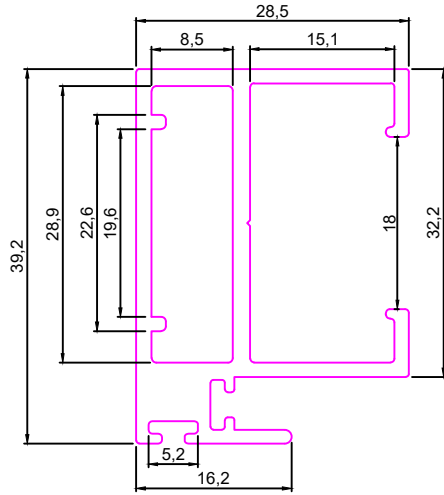

SEC No. VA7924

Weight:-2.500Kg/12'

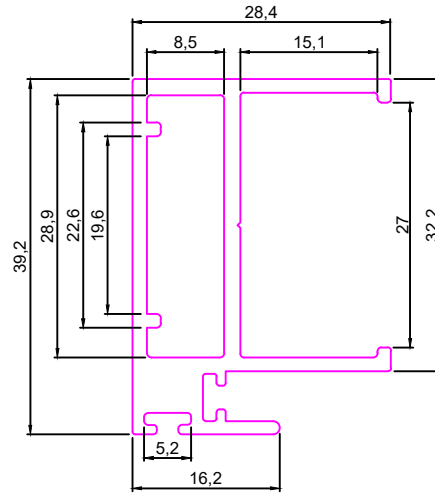

SEC No. 7946

Weight:-5.400Kg/12'

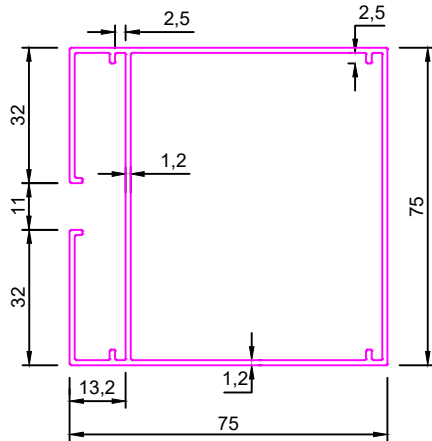

SEC No. 7964

Weight:-4.200Kg/12'

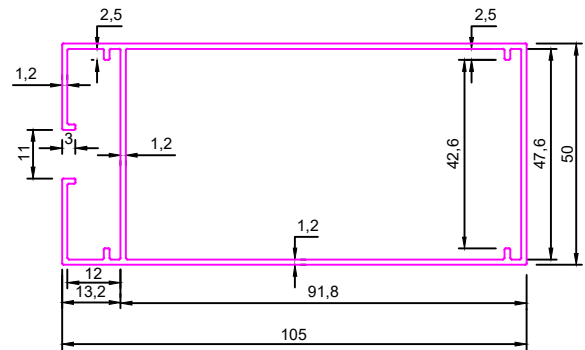

SEC No. 7993

Weight:-3.825Kg/12'

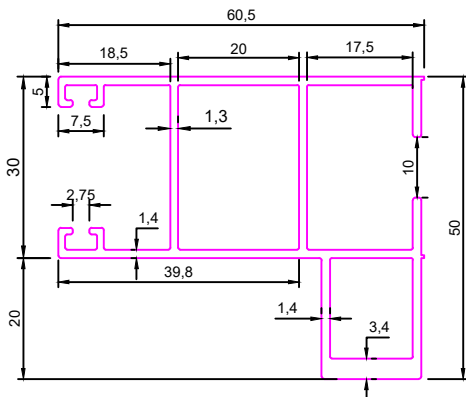

SEC No. 7994

Weight:-3.592Kg/12'

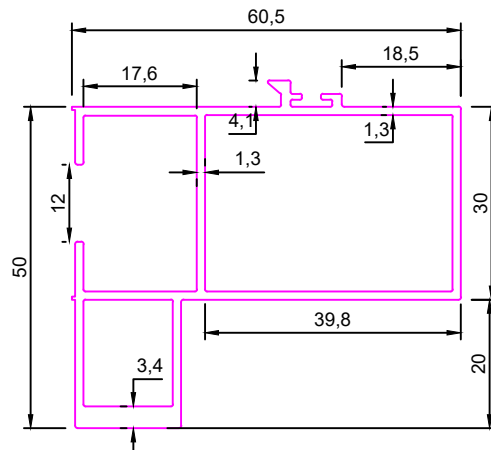



SLIDING WINDOW

SEC No. 8059

Weight:-2.785Kg/12'

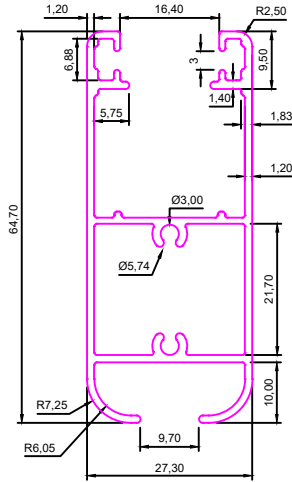

SEC No:- 8101

Weight:-1.600Kg/12'

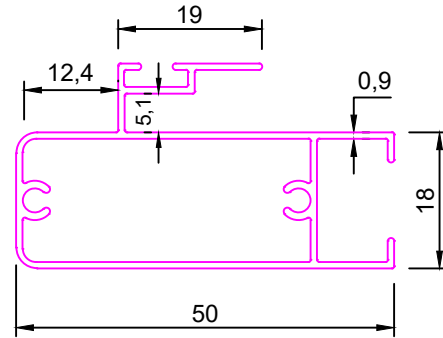

SEC No. 8134

Weight:-1.715Kg/12'

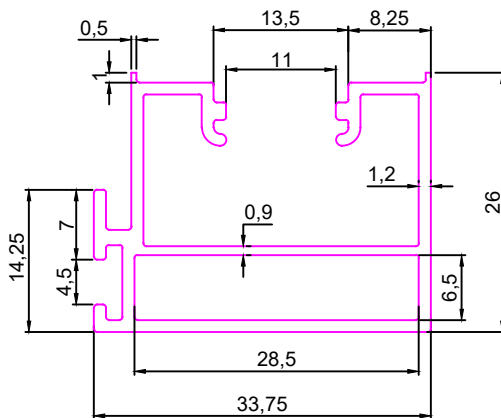

SEC No. 8135

Weight:-4.475Kg/12'

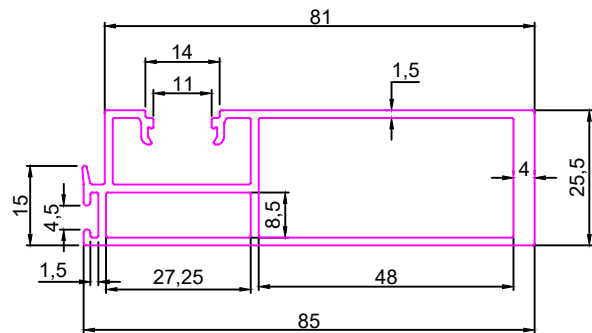

SEC No. 8140

Weight:-0.500Kg/12'

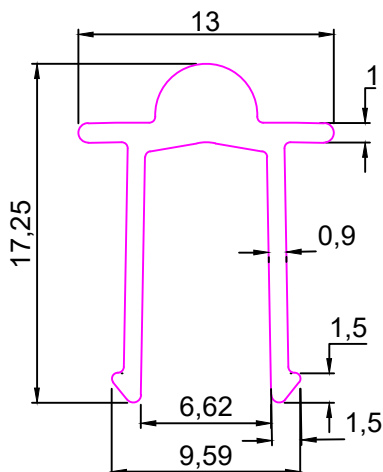

SEC No. 8160

Weight:-1.220Kg/12'

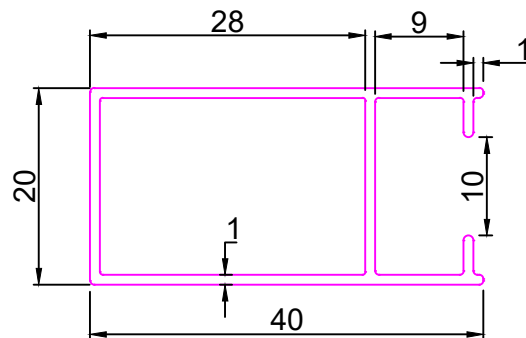



SLIDING WINDOW

SEC No. 8161

Weight:-1.380Kg/12'

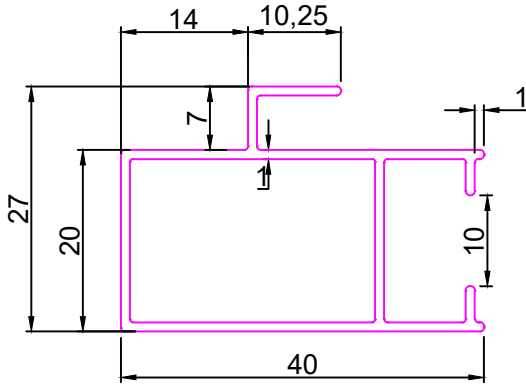

SEC No. 8306

Weight:-1.150Kg/12'

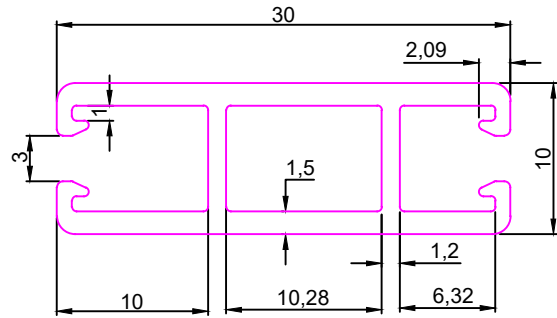

SEC No. 8307

Weight:-2.200Kg/12'

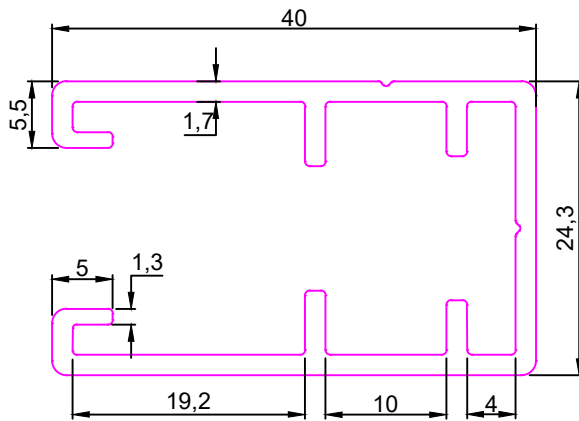

SEC No. 8314

Weight:-2.600Kg/12'

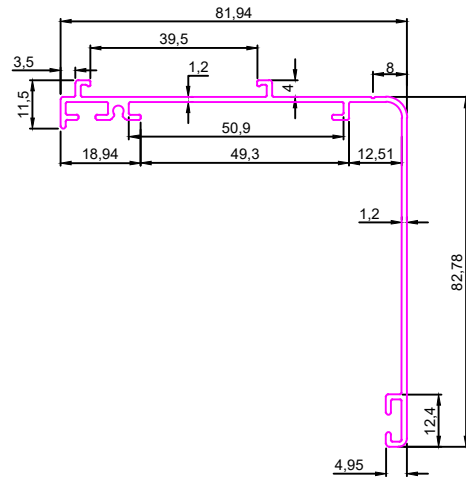

SEC No. 8327

Weight:-1.260Kg/12'

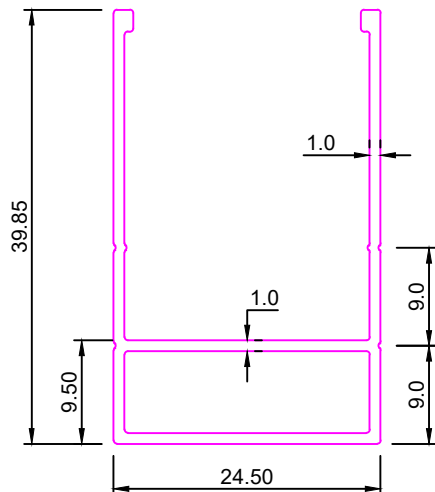

SEC No. 8329

Weight:-6.000Kg/12'

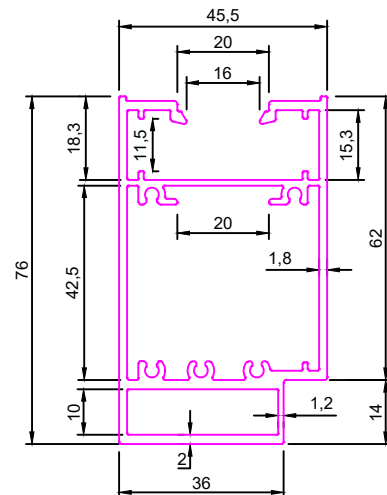



SLIDING WINDOW

SEC No. 8334

Weight:-1.200Kg/12'

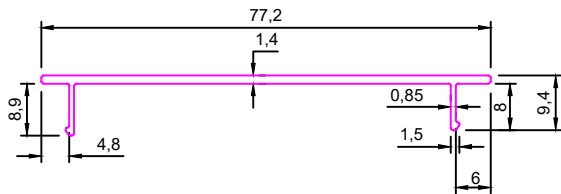

SEC No. 8355

Weight:-6.100Kg/12'

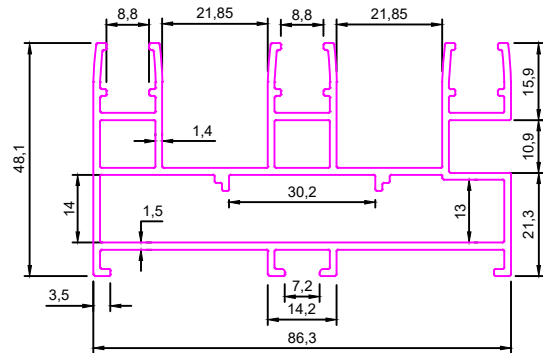

SEC No. 8356

Weight:-3.810Kg/12'

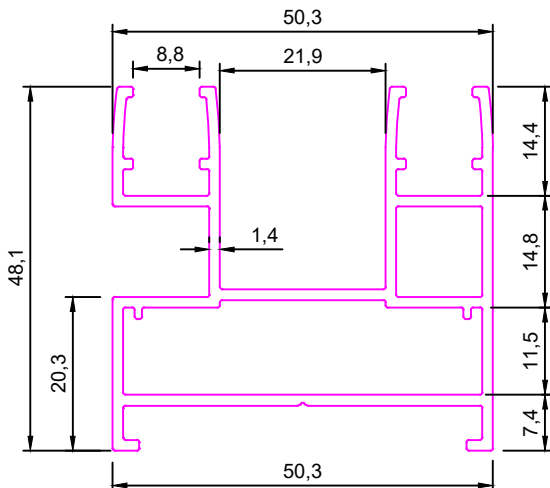

SEC No. 8357

Weight:-0.550Kg/12'

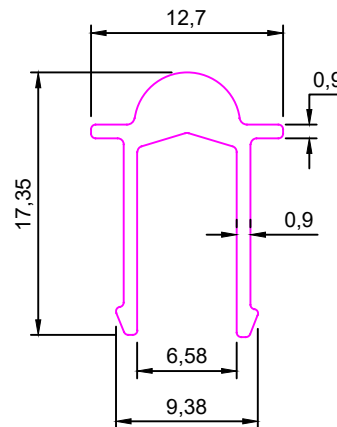

SEC No. 8358

Weight:-3.300Kg/12'

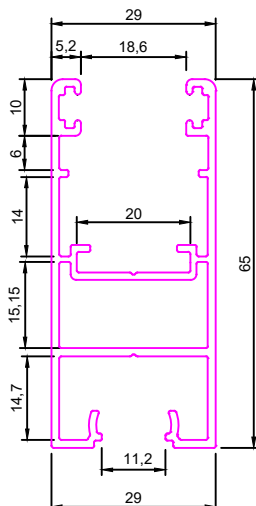

SEC No. 8359

Weight:-3.000Kg/12'

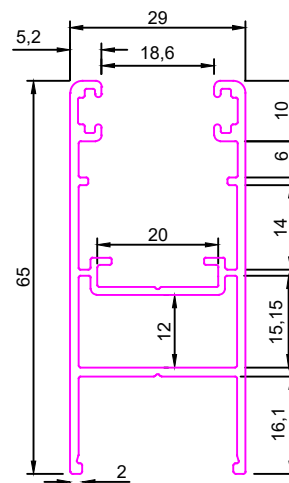



SLIDING WINDOW

SEC No. 8360

Weight:-1.150Kg/12'

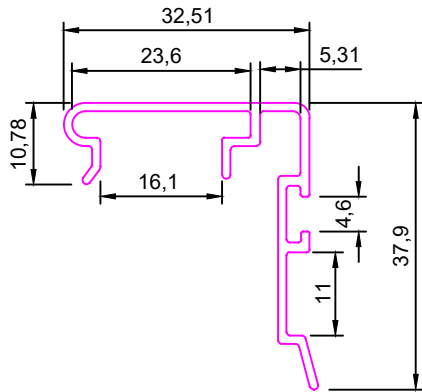

SEC No. 8361

Weight:-1.800Kg/12'

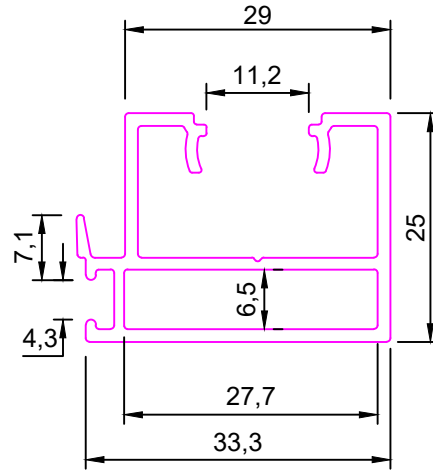

SEC No. 8469

Weight:-2.800Kg/12'

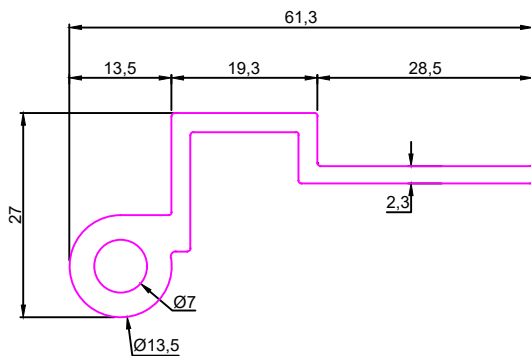

SEC No. 8470

Weight:-2.600Kg/12'

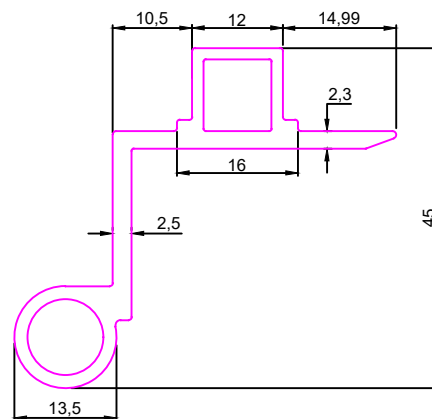

SEC No. 8471

Weight:-2.050Kg/12'

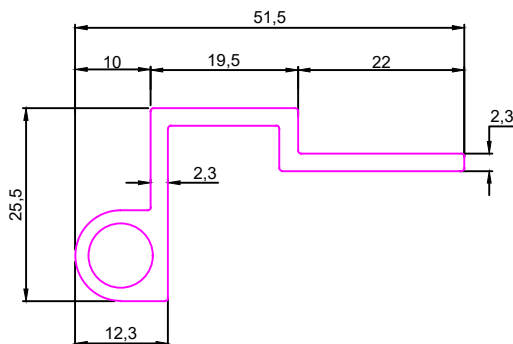

SEC No. 8472

Weight:-2.050Kg/12'

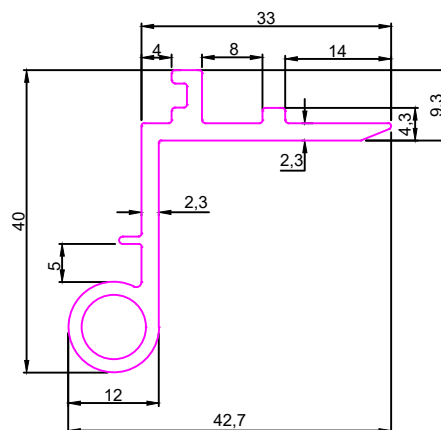



SLIDING WINDOW

SEC No. 8473

Weight:-2.450Kg/12'

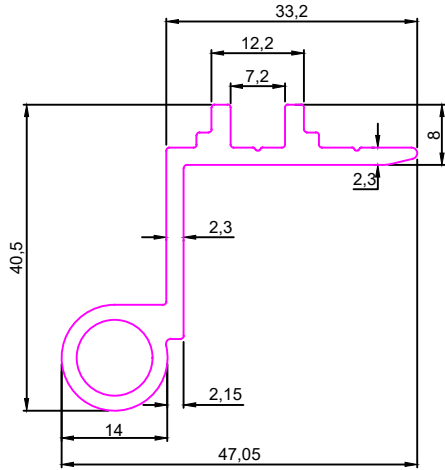

SEC No. 8474

Weight:-2.725Kg/12'

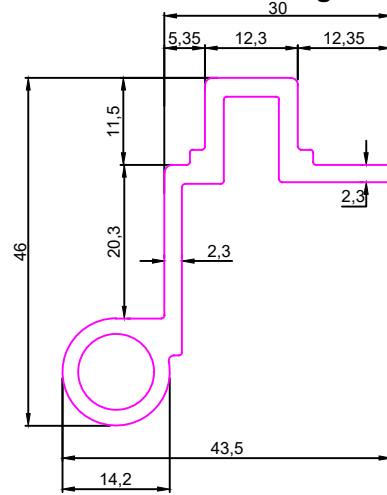

SEC No. 8550

Weight:3.595Kg/12'

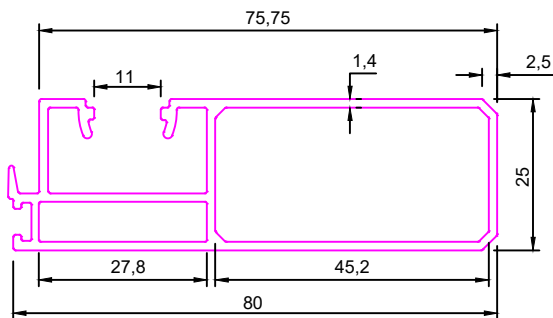

SEC No. 8551

Weight:1.560Kg/12'

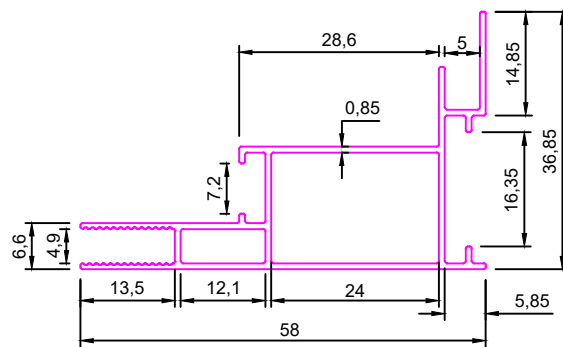

SEC No. 8562

Weight:7.900Kg/12'

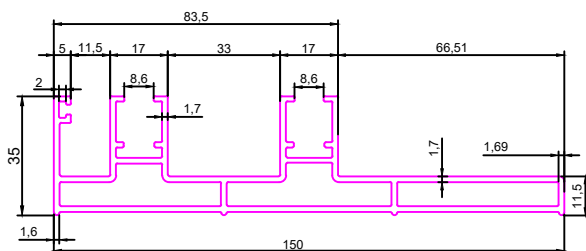

SEC No. 8580

Weight:1.725Kg/12'

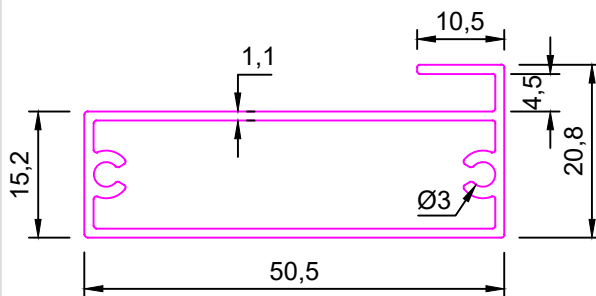



SLIDING WINDOW

SEC No. GA8730

Weight:-2.000Kg/12'

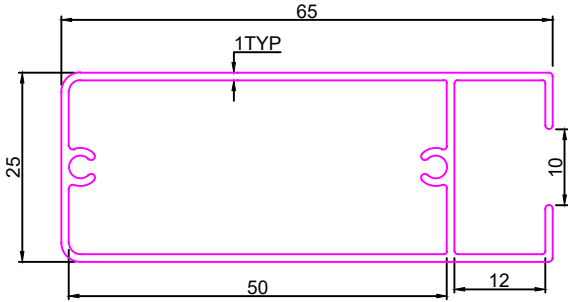

SEC No. GA8731

Weight:-2.350Kg/12'

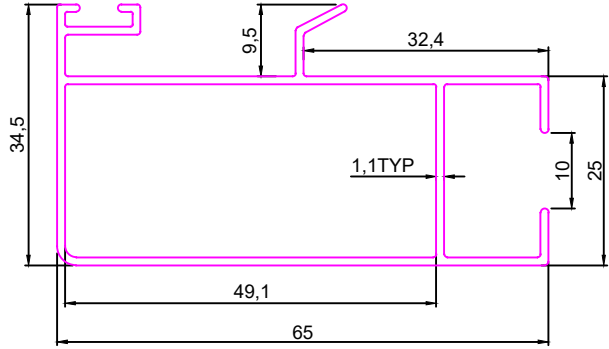

SEC No. GA8732

Weight:-2.355Kg/12'

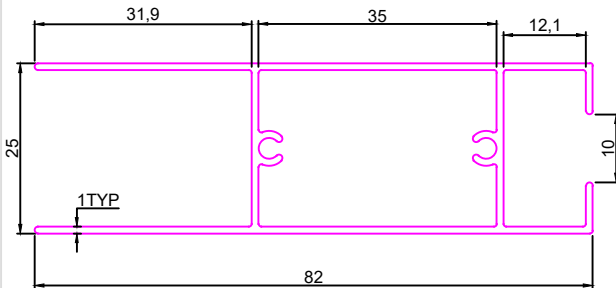

SEC No. 8737

Weight:-1.200Kg/12'

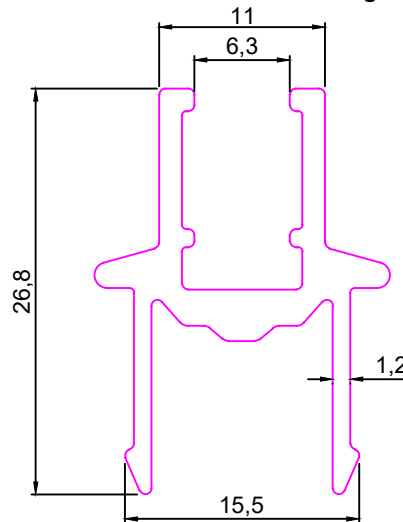

SEC No.:- 8777

Weight:-2.185Kg/12'

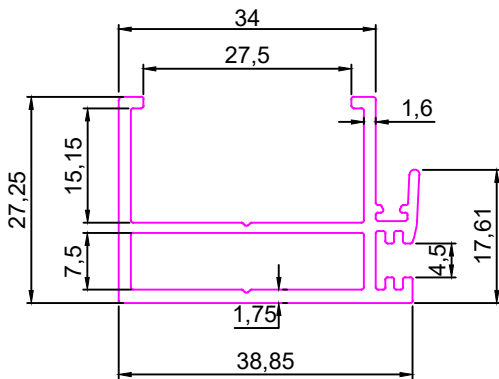

SEC No.:- 8778

Weight:-3.815Kg/12'

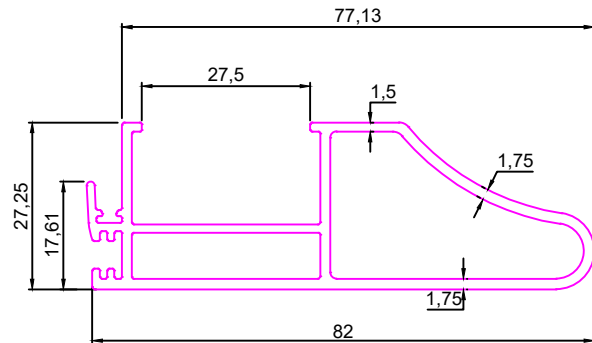



SLIDING WINDOW

SEC No.:- 8779

Weight:-4.950Kg/12'

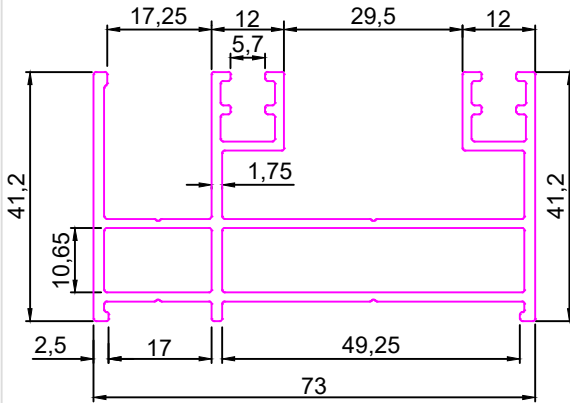

SEC No.:- 8780

Weight:-7.230Kg/12'

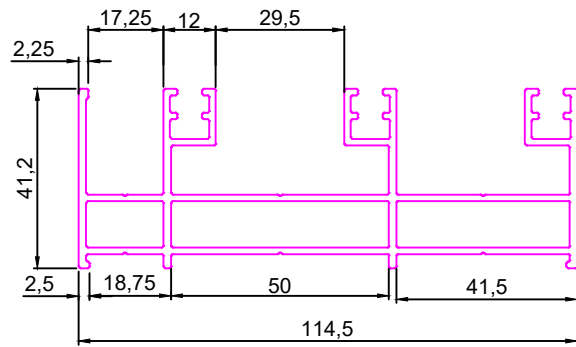

SEC No.:- 8781

Weight:-3.290Kg/12'

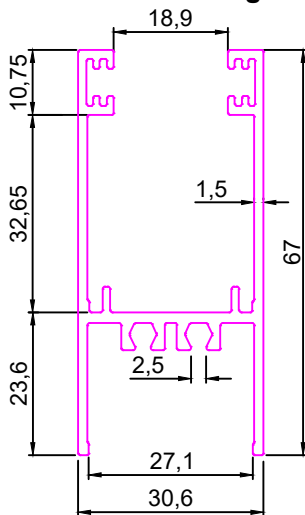

SEC No.:- 8782

Weight:-3.565Kg/12'

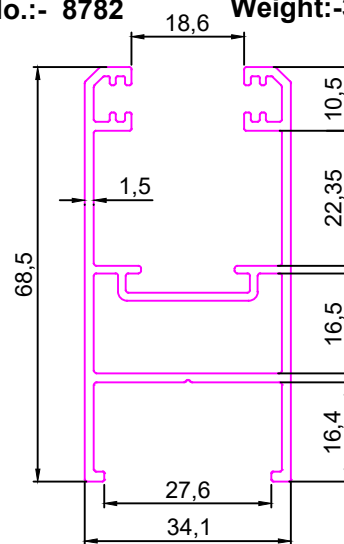

SEC No.:- 8783

Weight:-0.850Kg/12'

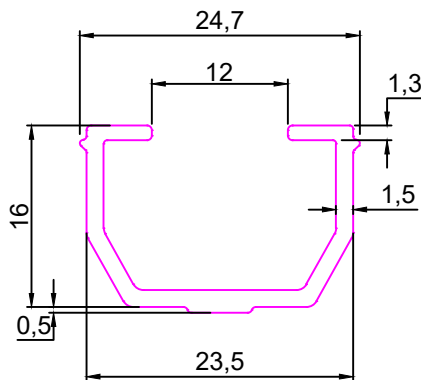

SEC No.:- 8785

Weight:-6.340Kg/12'

