



**SURAT
ALLUMINIUM COMPANY**



HINDVER ALUMINIUM

Glass-Series

Index Box

| Sr. No. | Profile Name | Page Number | Remarks |
|----------------|---------------------|--------------------|----------------|
| 1. | Glass Series | 1 - 3 | 3 |
| | | | |
| | | | |
| | | | |
| | | | |
| | | | |
| | | | |
| | | | |
| | | | |
| | | | |
| | | | |
| | | | |





GLASS-SERIES

SEC. NO:-2621

Weight :- 2.090kg/12'

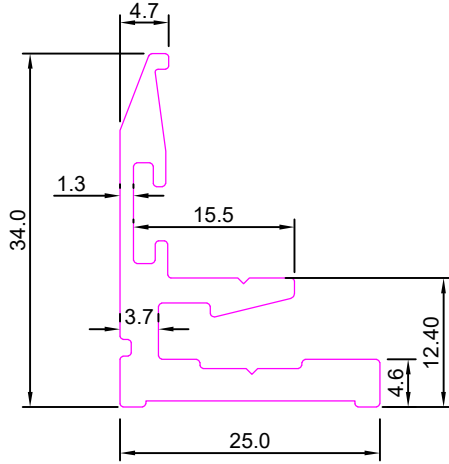

SEC. NO:-2623

Weight :- 1.220kg/12'

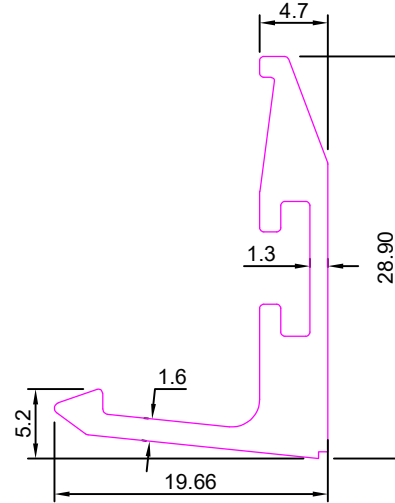

SEC. NO:-2625

Weight :- 9.370kg/12'

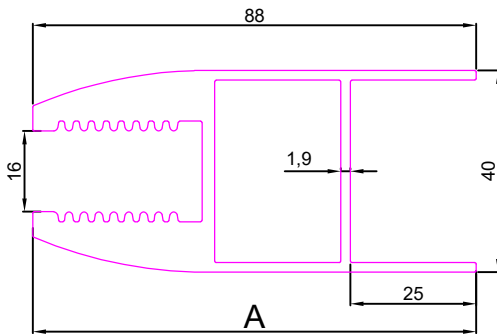

SEC. NO:-2631

Weight :- 6.265kg/12'

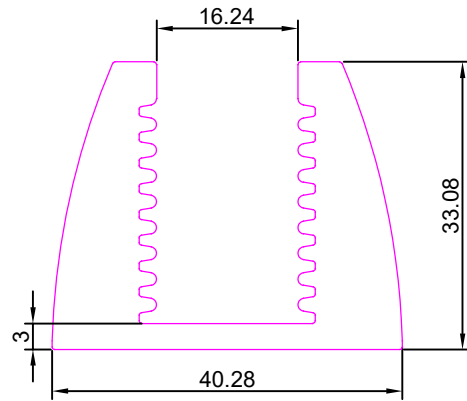

SEC. NO:-2636

Weight :- 2.410kg/12'

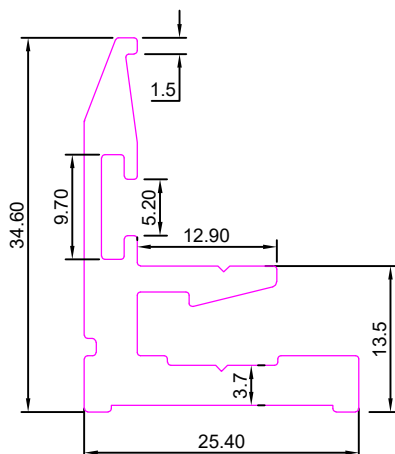

SEC. NO:-2637

Weight :- 1.300kg/12'

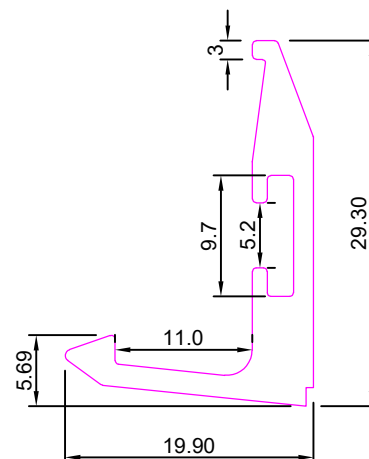



GLASS-SERIES

SEC. NO:-2641

Weight :- 10.000kg/12'

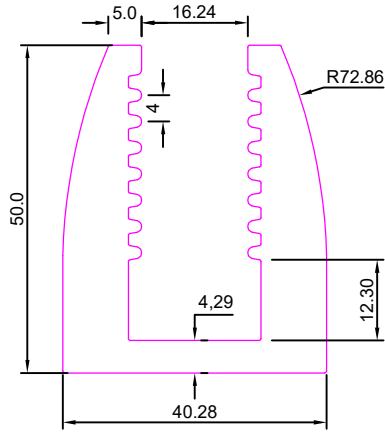

SEC. NO:-2646

Weight :- 3.540kg/12'

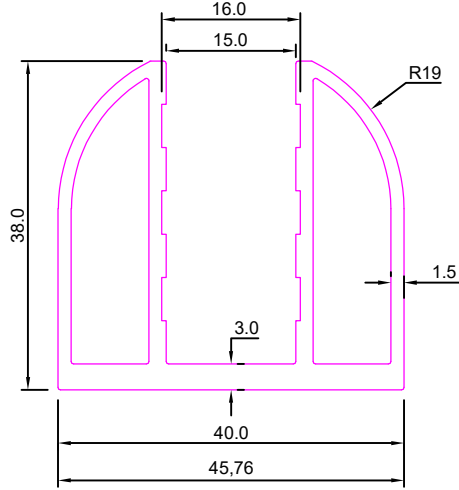

SEC No. 7322

Weight :-1.160kg/12'

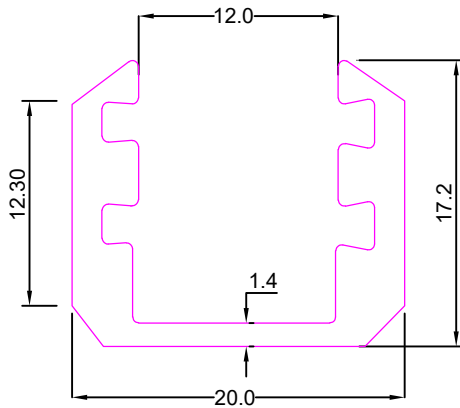

SEC No. 8221

Weight:-3.650Kg/12'

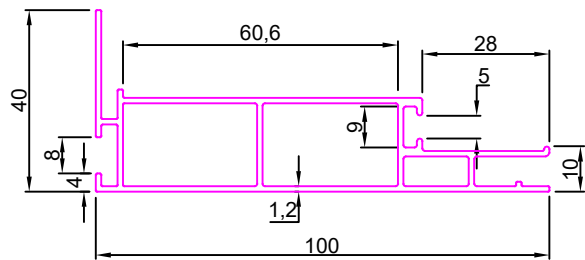

SEC No. 8222

Weight:-1.000Kg/12'

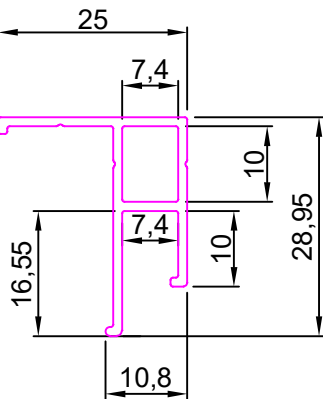

SEC No. :-8272

Weight:-7.717Kg/12'

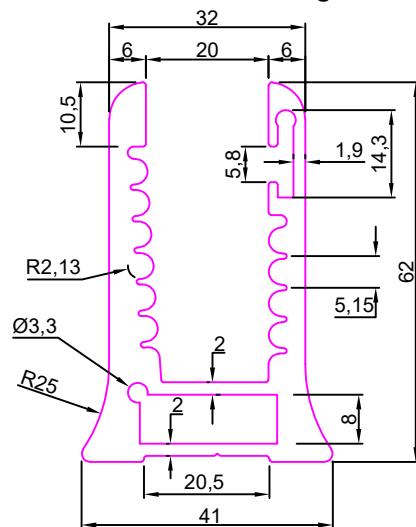



GLASS SERIES

SEC No. :-VA8273

Weight:-0.734Kg/12'

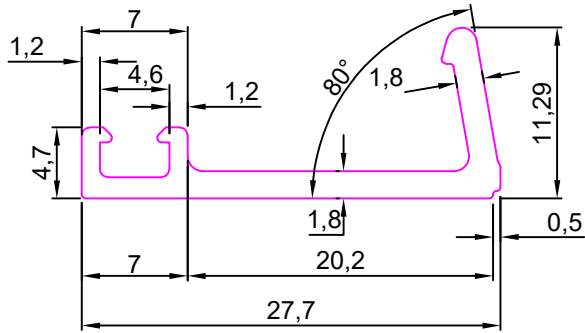

SEC No. 8302

Weight:-1.000Kg/12'

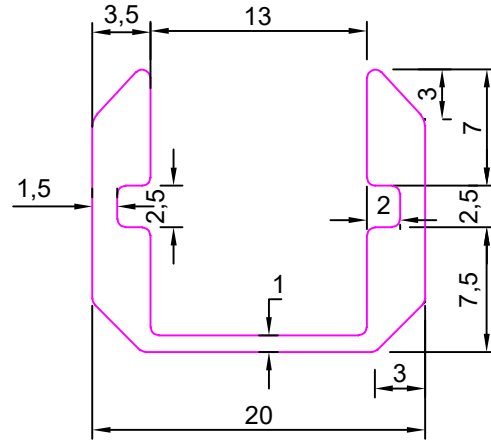

SEC No. 8315

Weight:-0.930Kg/12'

