

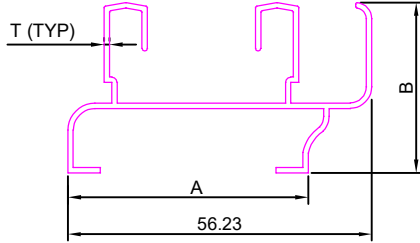

3/4" - DOMAL SERIES

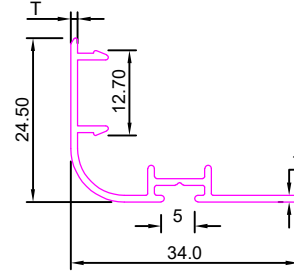

SECTION NO	A	B	T	Wt. (KG/Mtr)	W.T RANGE KG/12'
3401	44.50	31.50	1.00	0.465	1.100-1.200
3402	44.50	31.50	1.20	0.546	1.200-1.400
3403	44.50	31.50	1.50	0.750	1.400-1.550



SECTION NO	T	Wt. (KG/Mtr)	W.T RANGE KG/12'
3411	1.00	0.192	0.700-0.800
3412	1.20	0.229	0.850-0.950

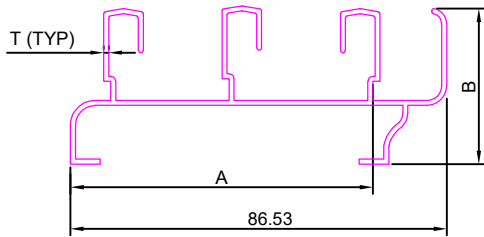

SECTION NO	A	B	T	Wt. (KG/Mtr)	W.T RANGE KG/12'
3421	74.50	31.50	1.00	0.660	2.400-2.600
3422	74.50	31.50	1.20	0.792	2.900-3.200
3423	74.50	31.50	1.50	0.990	3.600-3.900

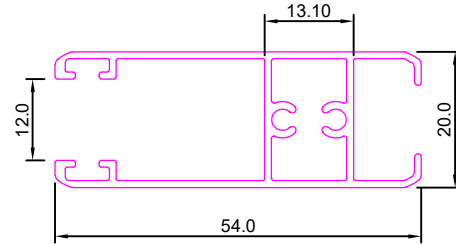

SECTION NO	T	Wt. (KG/Mtr)	W.T RANGE KG/12'
3431	0.90	0.464	1.700-1.850
3432	1.00	0.520	1.900-2.100
3433	1.20	0.610	2.200-2.400
3434	1.35	0.670	2.450-2.700

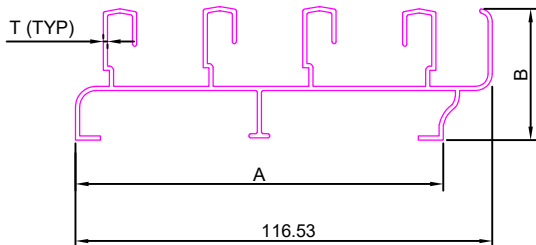

SECTION NO	A	B	T	Wt. (KG/Mtr)	W.T RANGE KG/12'
3441	74.50	31.50	1.00	0.660	2.400-2.600
3442	74.50	31.50	1.20	0.792	2.900-3.200

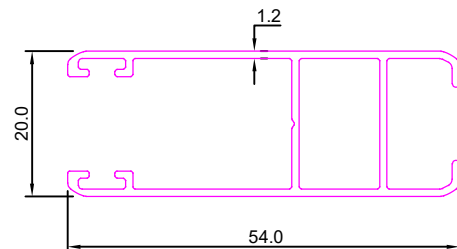

SECTION NO	T	Wt. (KG/Mtr)	W.T RANGE KG/12'
3451	1.20	0.532	1.950-2.150
3452	1.50	0.665	2.400-2.600



1" DOMAL SERIES

SEC. NO:-3501

Weight :- 1.020kg/12'

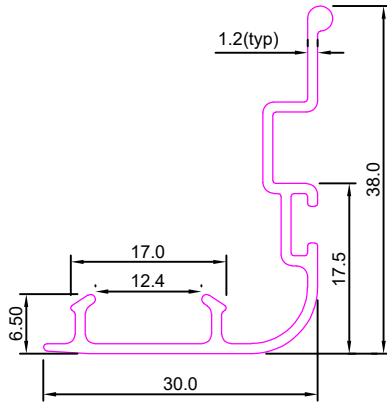

SEC. NO:-3503

Weight :- 3.160kg/12'

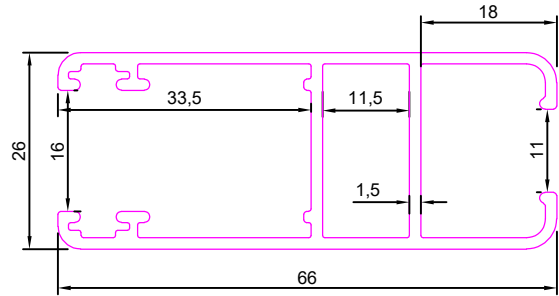

SEC. NO:-3505

Weight :-6.700kg/12'

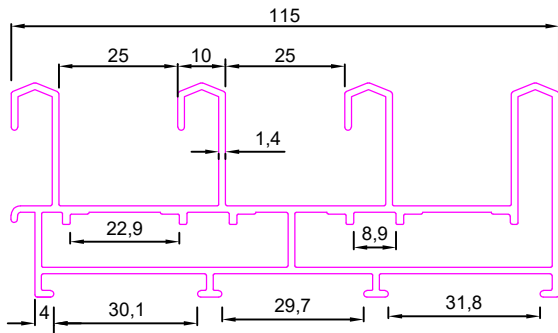

SEC. NO:-3507

Weight :- 2.930kg/12'

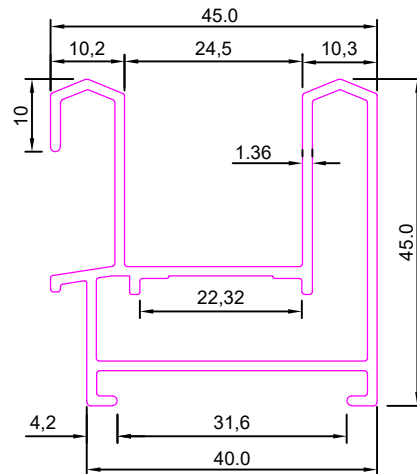

SEC. NO:-3509

Weight :- 4.630kg/12'

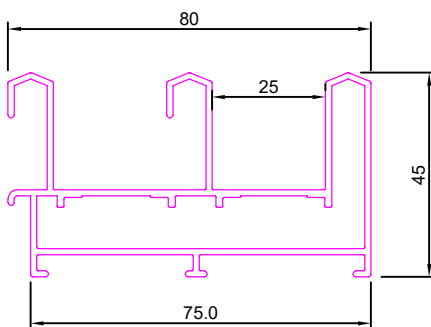

SEC. NO:-3511

Weight :- 5.300kg/12'

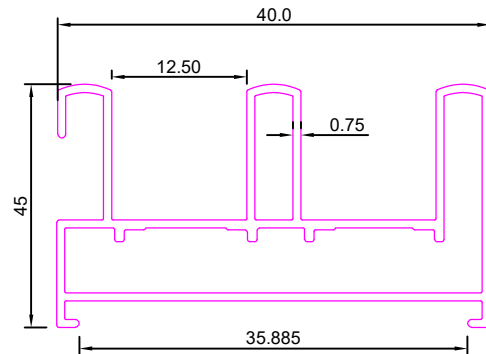



DOMAL SERIES

SEC. NO:-3551

Weight :- 2.775kg/12'

Euro Shutter

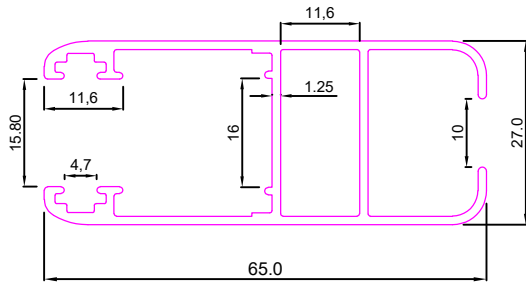

SEC. NO:-3553

Weight :- 1.000kg/12'

Euro Clip

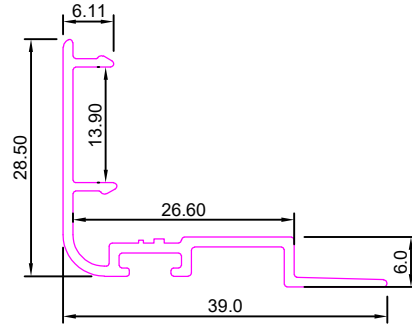

SEC. NO:-3555

Weight :- 2.840kg/12'

27x60 Shutter

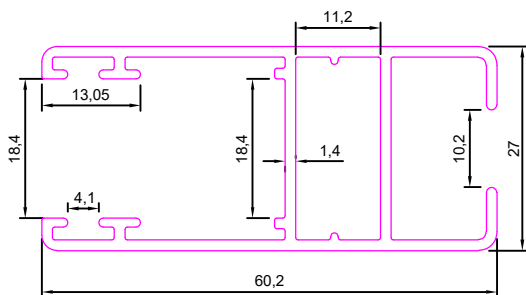

SEC. NO:-3557

Weight :- 1.260kg/12'

27x60 Clip

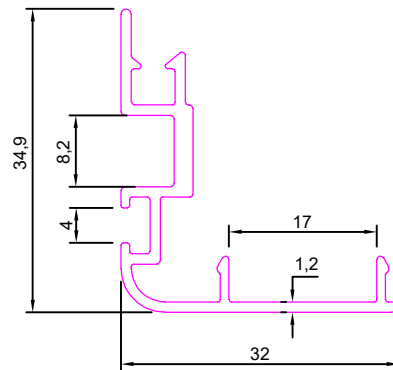

SEC. NO:-3559

Weight :- 2.755kg/12'

Shutter

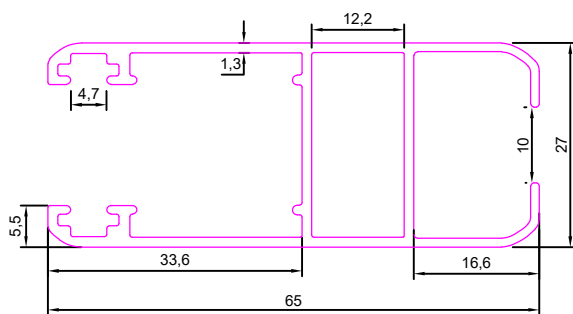

SEC. NO:-3561

Weight :-1.00kg/12'

Clip

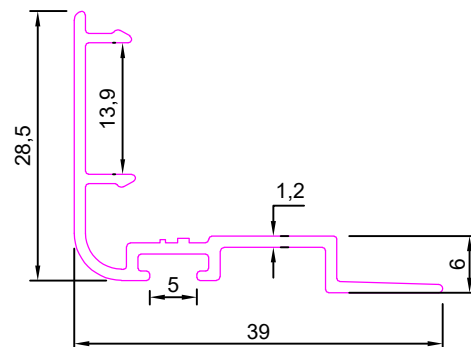



DOMAL SERIES

SEC. NO:-3563

Weight :- 3.080kg/12'

Double Glass Shutter

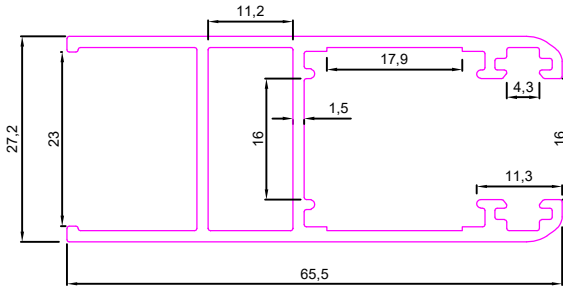

SEC. NO:-3565

Weight :- 2.850kg/12'

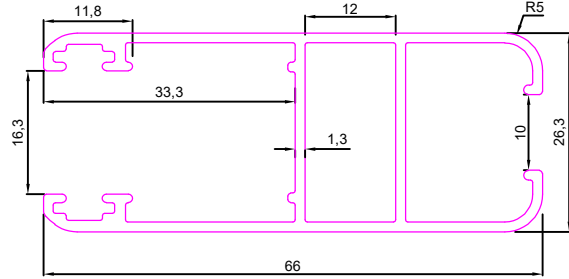

SEC. NO:-3567

Weight :- 1.000kg/12'

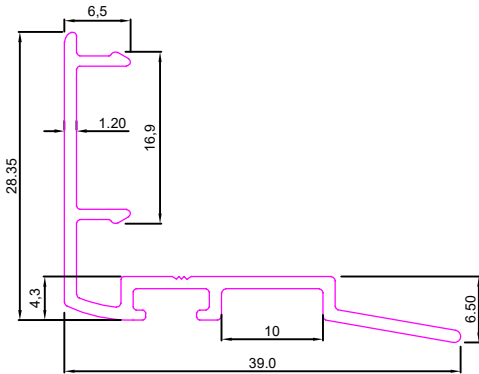

SEC. NO:-3569

Weight :- 4.660kg/12'

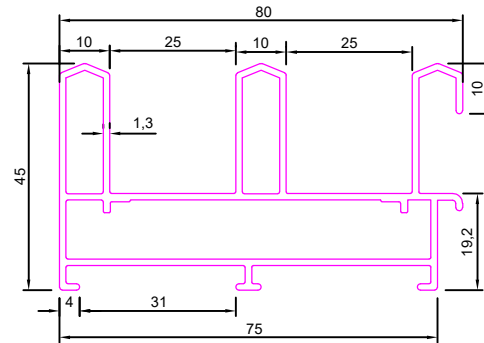

SEC. NO:-3571

Weight :- 2.930kg/12'

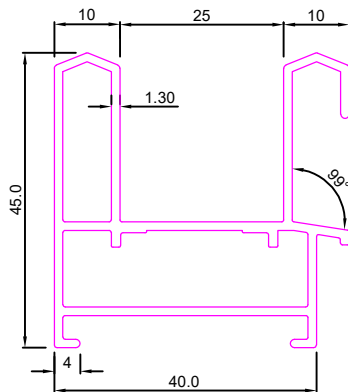

SEC. NO:-3573

Weight :- 2.530kg/12'

22mm Shutter

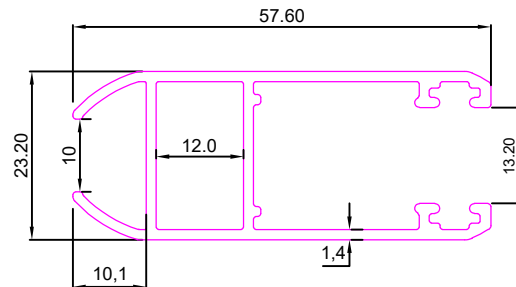



DOMAL SERIES

SEC. NO:-3575

Weight :- 0.800kg/12'

22mm Clip

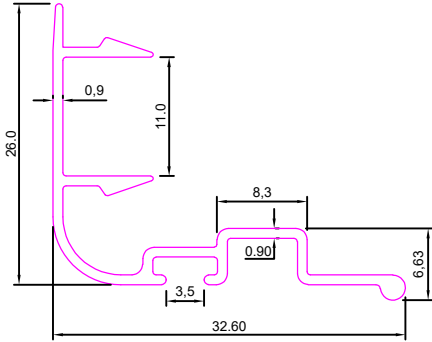

SEC. NO:-3577

Weight :- 2.360kg/12'

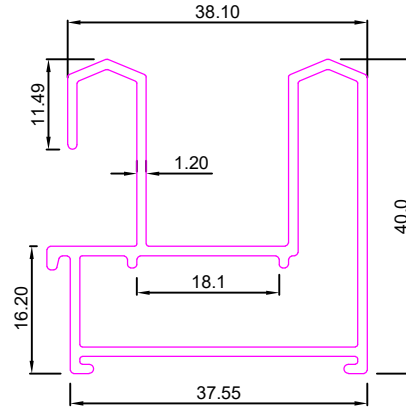

SEC. NO:-3579

Weight :- 3.560kg/12'

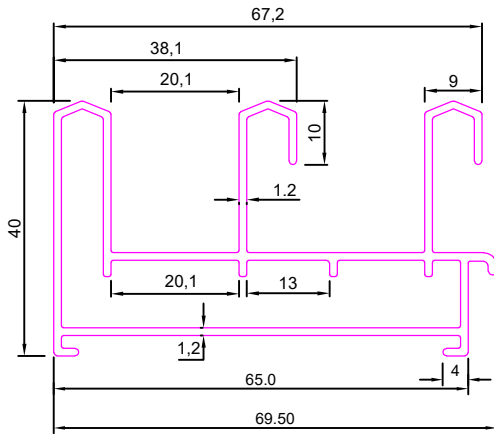

SEC. NO:-3601

Weight :- 1.880kg/12'

22mm R. SHAPE

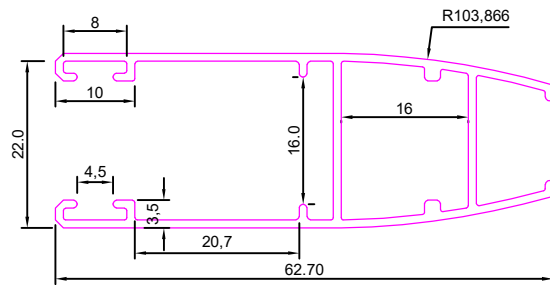

SEC. NO:-3603

Weight :- 0.645kg/12'

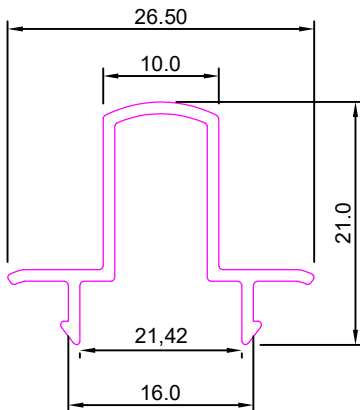

SEC. NO:-3606

Weight :- 1.000kg/12'

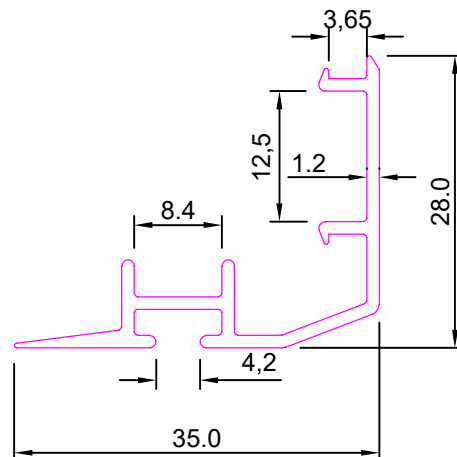



DOMAL SERIES

SEC. NO:-3607

Weight :- 3.860kg/12'

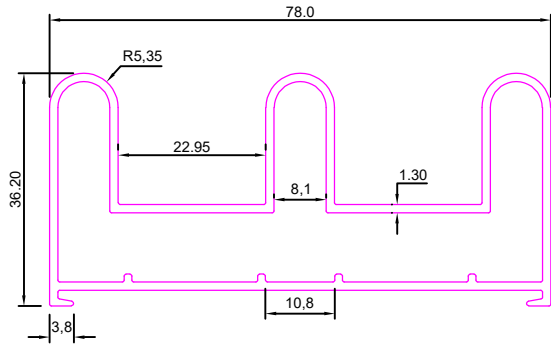

SEC. NO:-3609

Weight :- 2.500kg/12'

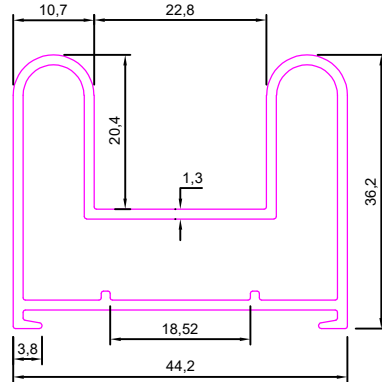

SEC. NO:-3621

Weight :- 5.115kg/12'

35mm Domal

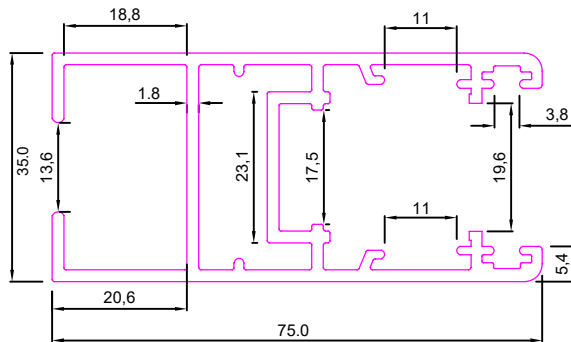

SEC. NO:-3623

Weight :- 1.390kg/12'

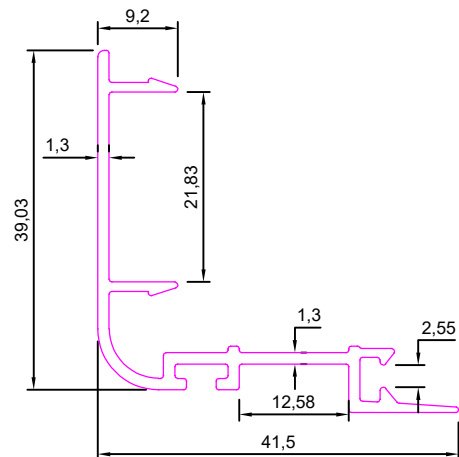

SEC. NO:-3625

Weight :- 4.845kg/12'

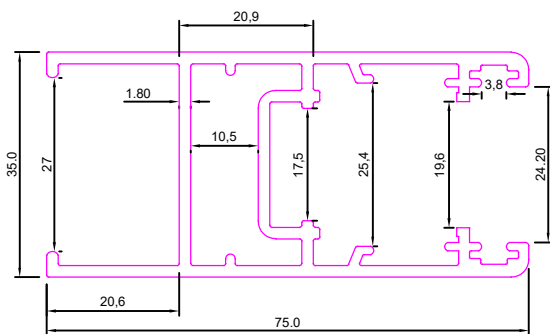

SEC. NO:-3627

Weight :- 3.390kg/12'

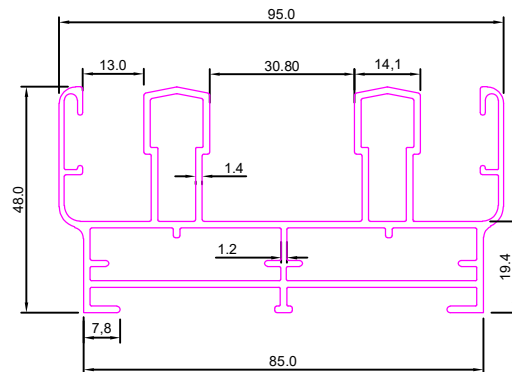



DOMAL SERIES

SEC. NO:-3629

Weight :- 8.760kg/12'

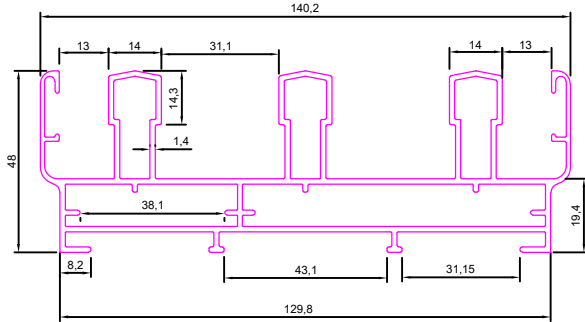

SEC. NO:-3651

Weight :- 2.965kg/12'

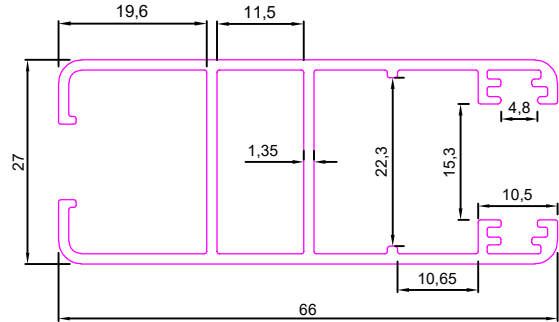

SEC. NO:-3653

Weight :- 1.900kg/12'

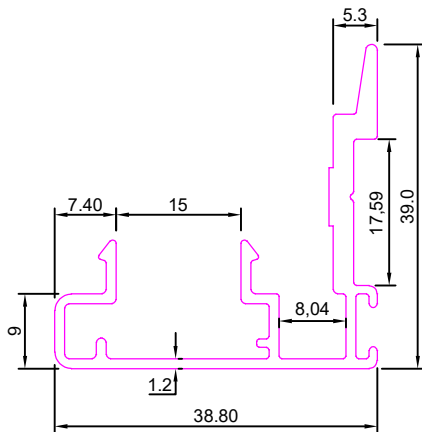

SEC. NO:-3655

Weight :- 4.310kg/12'

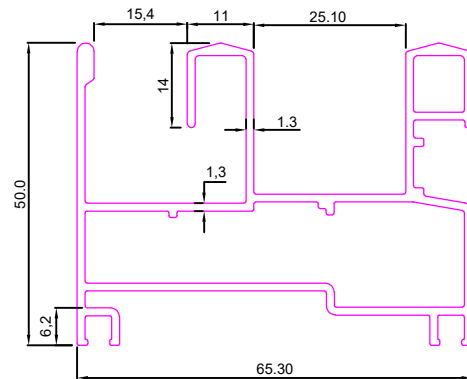

SEC. NO:-3657

Weight :- 6.820kg/12'

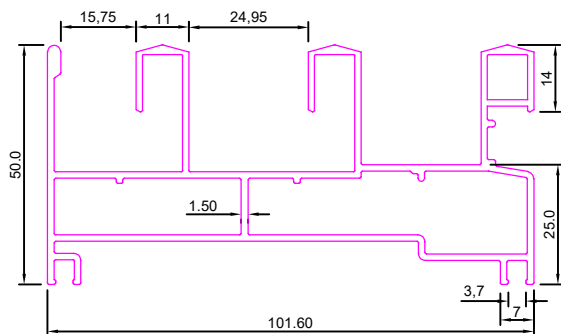

SEC. NO:-3671

Weight :- 3.225kg/12'

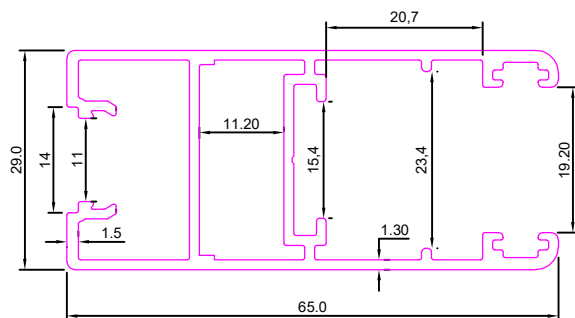



DOMAL SERIES

SEC. NO:-3673

Weight :-1.340kg/12'

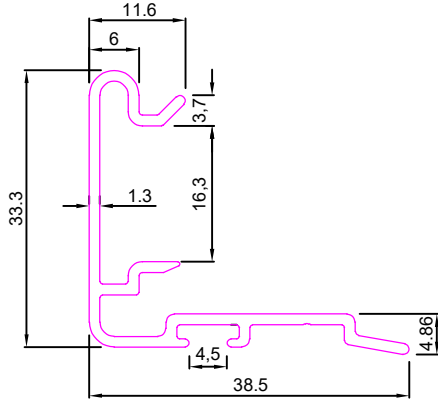

SEC. NO:-3675

Weight :-2.930kg/12'

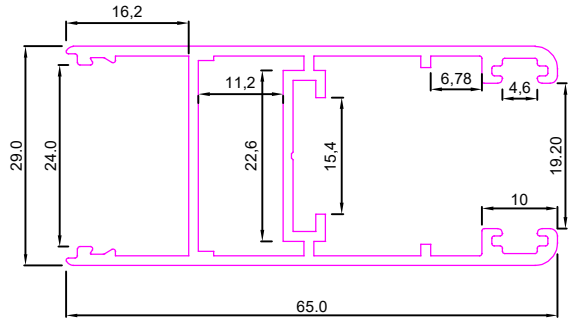

SEC. NO:-3677

Weight :- 3.900kg/12'

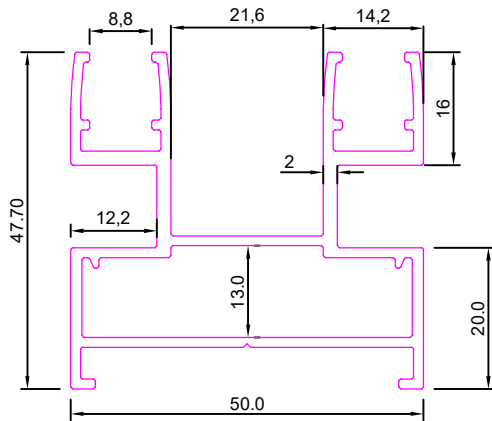

SEC. NO:-3679

Weight :- 6.300kg/12'

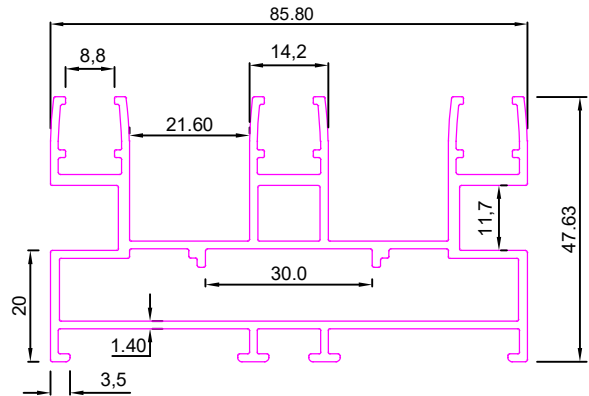

SEC. NO:-3681

Weight :- 0.530kg/12'

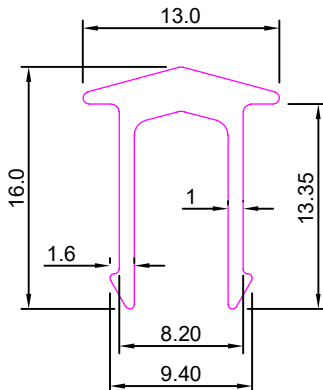

SEC. NO:-3683

Weight :- 1.400kg/12'

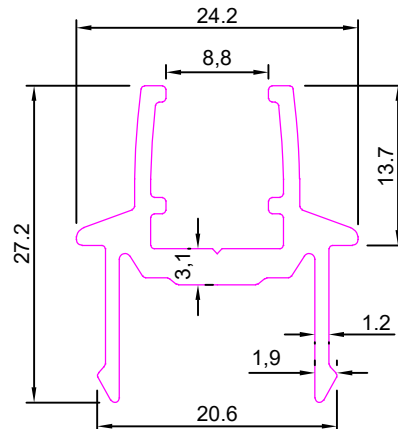



DOMAL SERIES

SEC. NO:-3685

Weight :- 2.115kg/12'

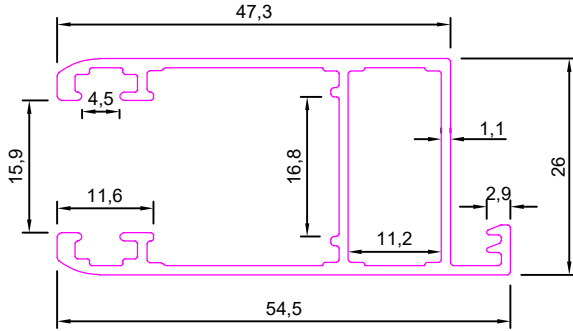

SEC. NO:-3687

Weight :- 1.000kg/12'

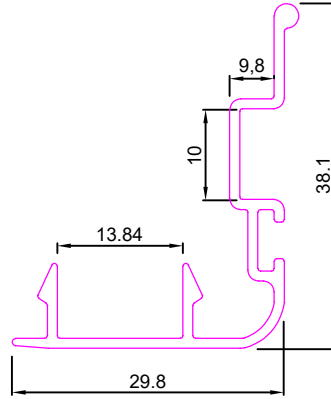

SEC. NO:-3689

Weight :- 2.990kg/12'

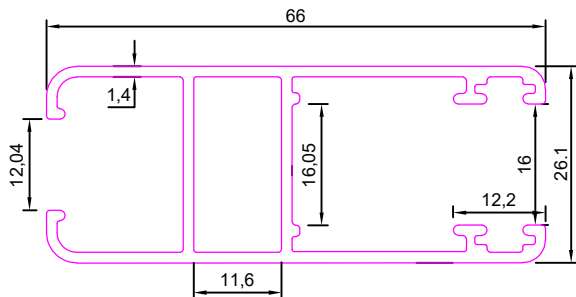

SEC. NO:-3691

Weight :- 1.775kg/12'

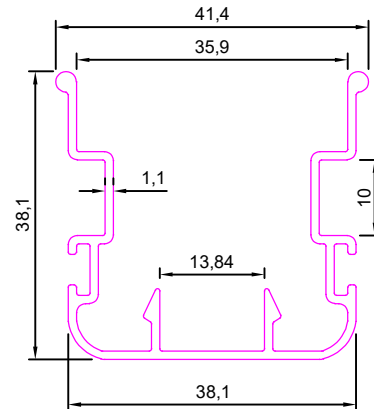

SEC. NO:-3693

Weight :- 3.800kg/12'

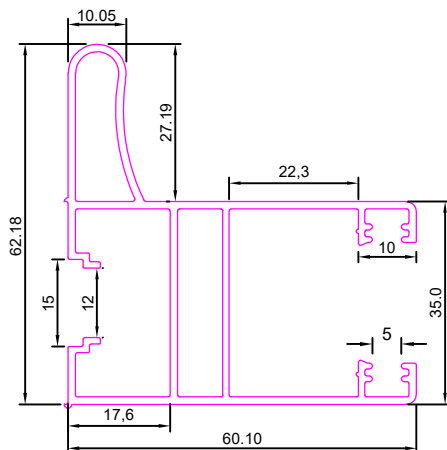

SEC. NO:-3695

Weight :- 3.270kg/12'

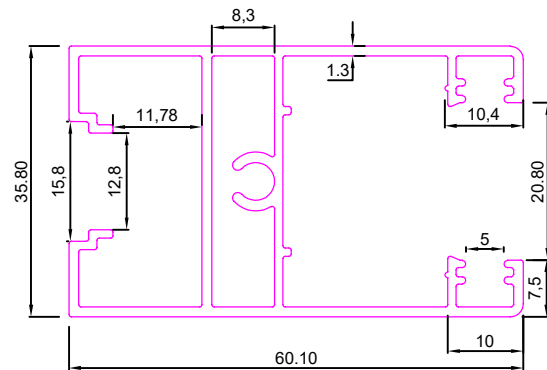



DOMAL SERIES

SEC. NO:-3697

Weight :- 3.100kg/12'

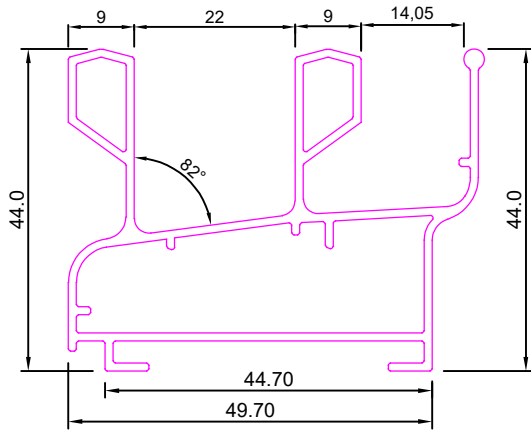

SEC. NO:-3699

Weight :- 2.900kg/12'

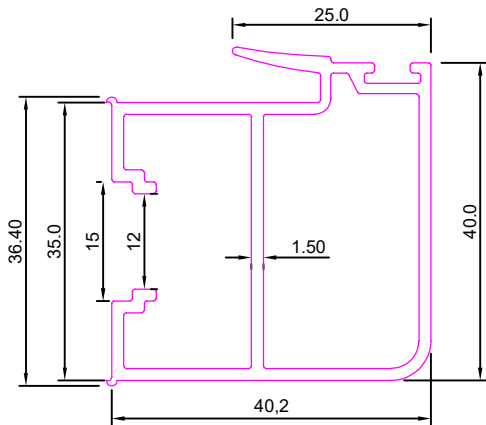

SEC. NO:-3701

Weight :- 6.175kg/12'

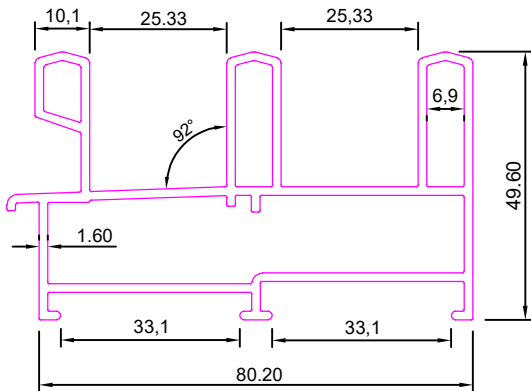

SEC. NO:-3703

Weight :- 0.325kg/12'

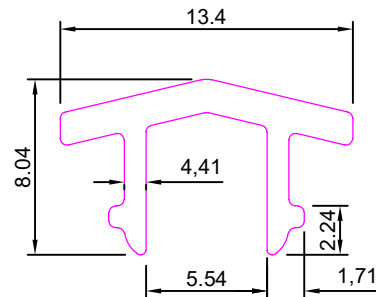

SEC. NO:-3705

Weight :- 7.045kg/12'

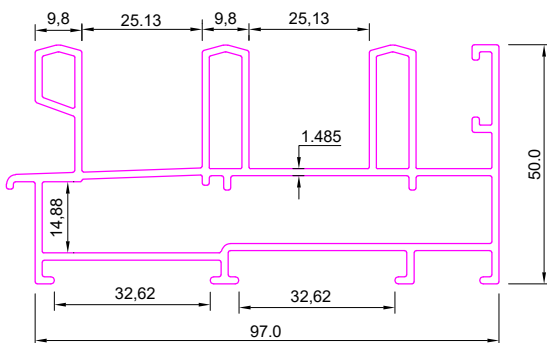

SEC. NO:-3721

Weight :- 1.675kg/12'

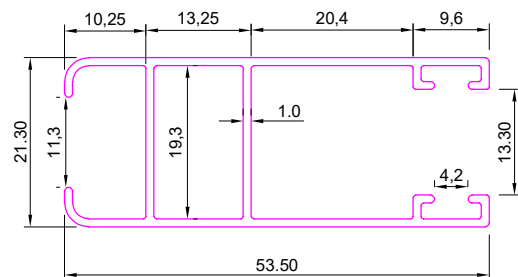



DOMAL SERIES

SEC. NO:-3723

Weight :- 0.770kg/12'

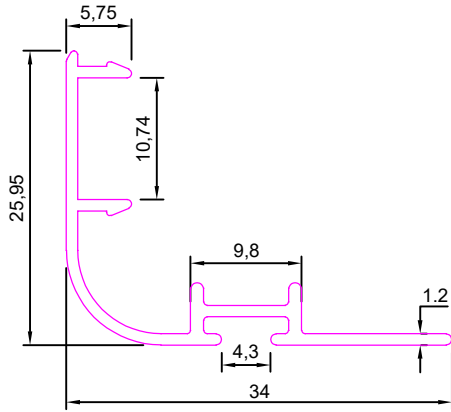

SEC. NO:-3725

Weight :- 2.155kg/12'

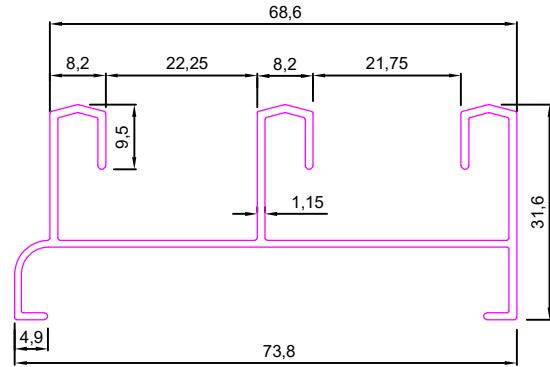

SEC. NO:-3727

Weight :- 1.520kg/12'

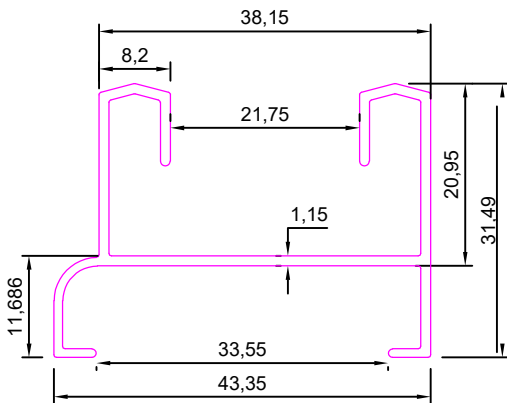

SEC. NO:-3729

Weight :- 2.250kg/12'

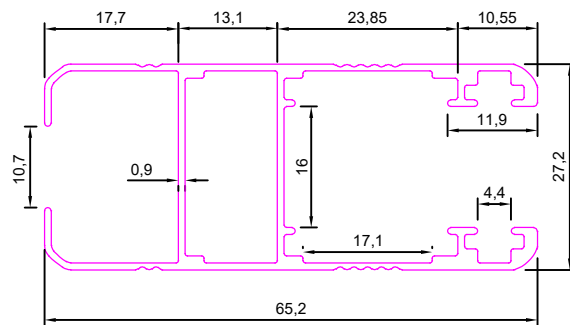

SEC. NO:-3731

Weight :- 1.195kg/12'

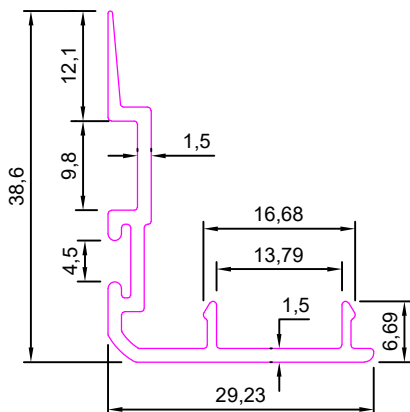

SEC. NO:-3733

Weight :- 0.425kg/12'

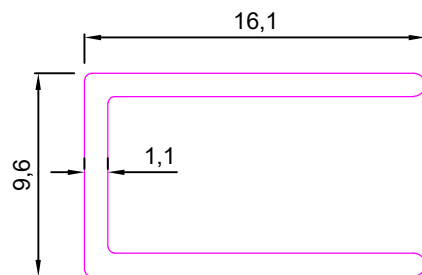



DOMAL SERIES

SEC. NO:-3735

Weight :- 5.110kg/12'

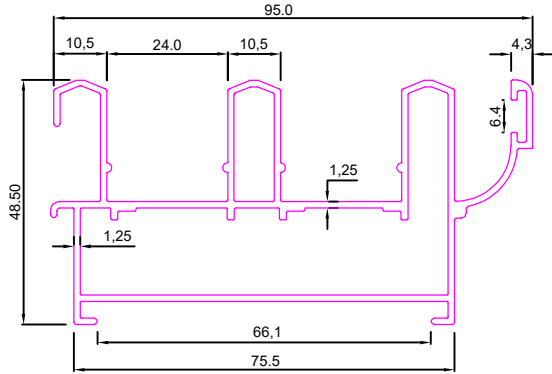

SEC. NO:-3771

Weight :- 6.755kg/12'

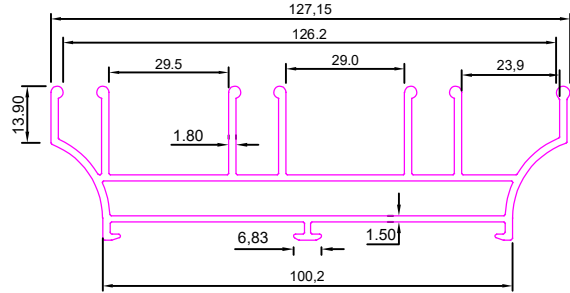

SEC. NO:-3773

Weight :- 4.500kg/12'

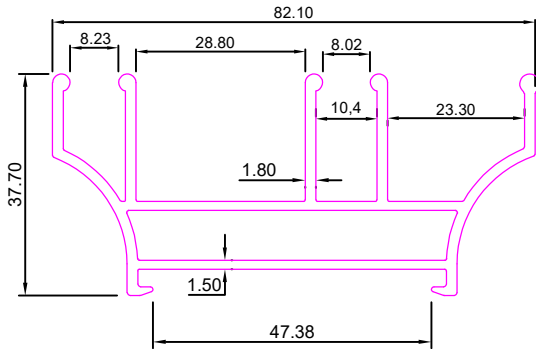

SEC. NO:-3775

Weight :- 4.700kg/12'

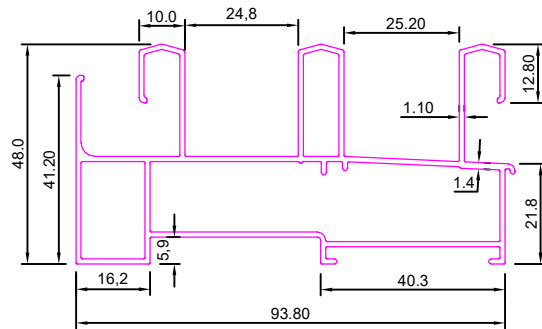

SEC. NO:-3785

Weight :- 3.700kg/12'

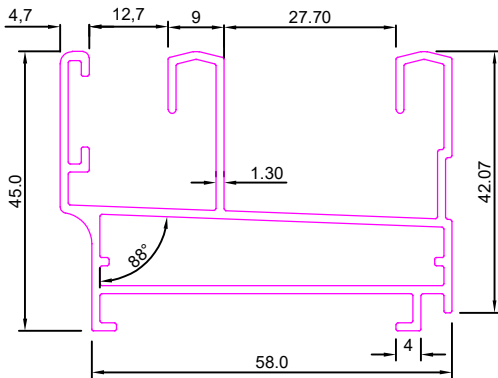

SEC. NO:-3787

Weight :- 2.350kg/12'

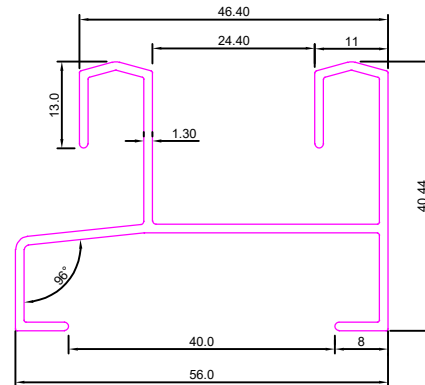



DOMAL SERIES

SEC. NO:-3789

Weight :-3.635kg/12'

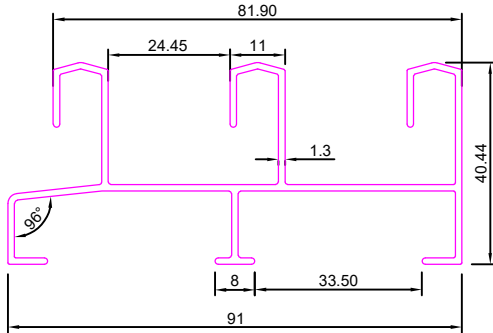

SEC. NO:-3791

Weight :- 5.325kg/12'

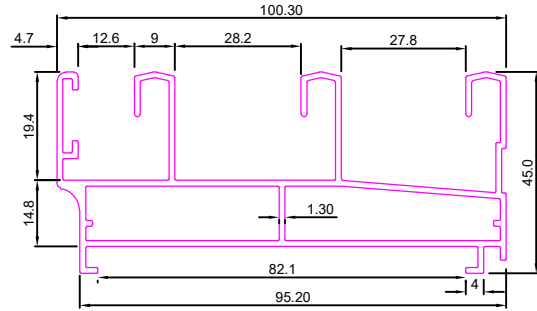

SEC. NO:- 3831

Weight :- 2.880kg/12'

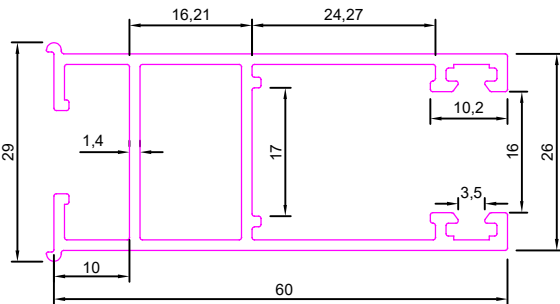

SEC. NO:- 3833

Weight :- 2.700kg/12'

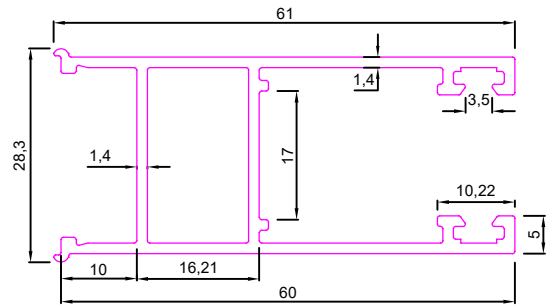

SEC. NO:- 3835

Weight :- 3.038kg/12'

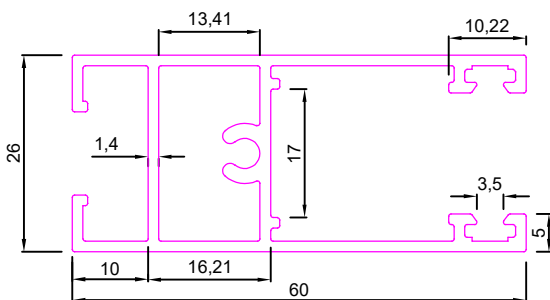

SEC. NO:- 3837

Weight :- 2.885kg/12'

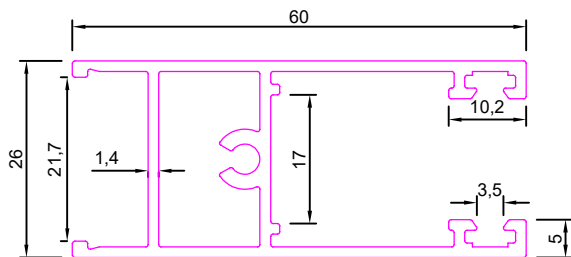



DOMAL SERIES

SEC. NO:- 3839

Weight :- 1.745kg/12'

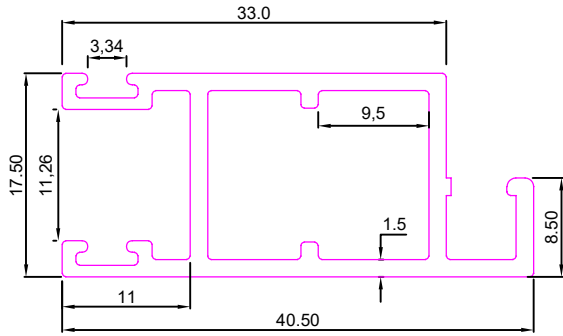

SEC. NO:- 3847

Weight :- 7.000-7.180kg/12'

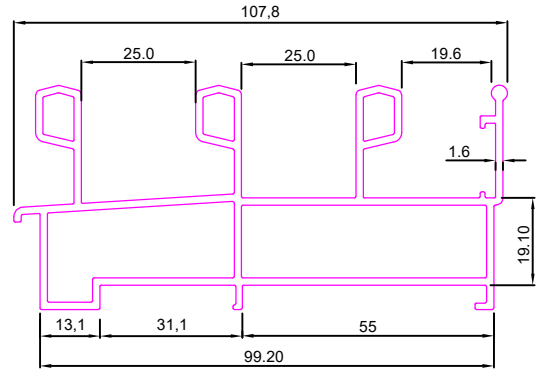

SEC. NO:- 3849

Weight :- 5.015kg/12'

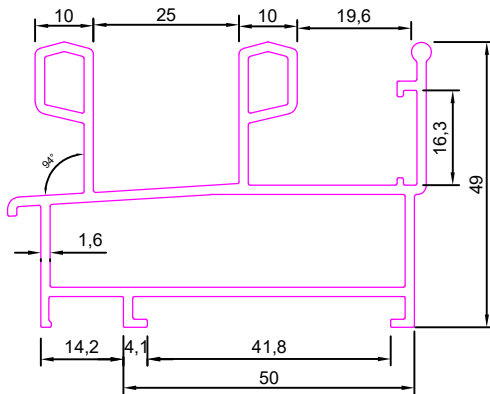

SEC No. 7235

Weight :- 4.950kg/12'

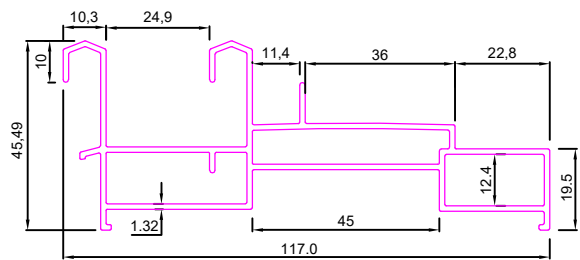

SEC No. 7236

Weight :- 5.700kg/12'

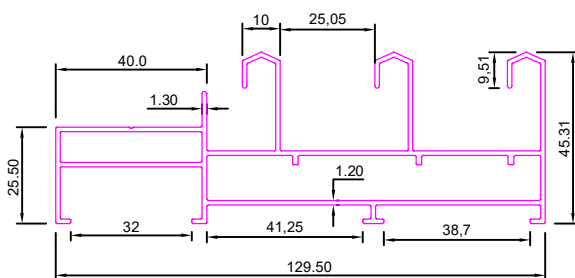

SEC No. 7241

Weight :- 4.050kg/12'

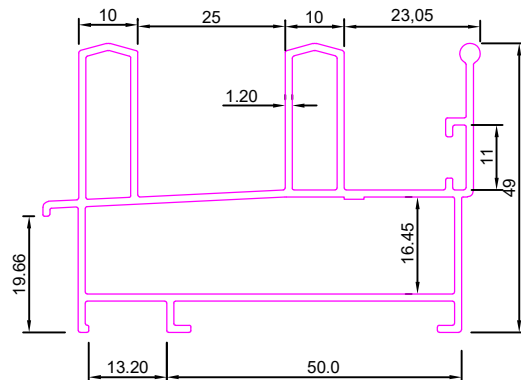



DOMAL SERIES

SEC No. 7242

Weight :-5.700kg/12'

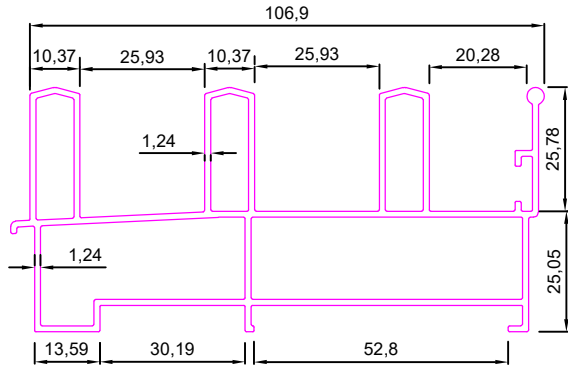

SEC No.7264

Weight :-0.500kg/12'

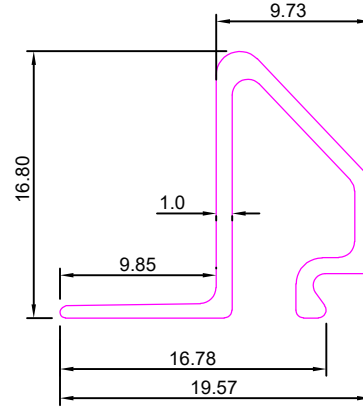

SEC No. 7265

Weight :- 2.650kg/12'

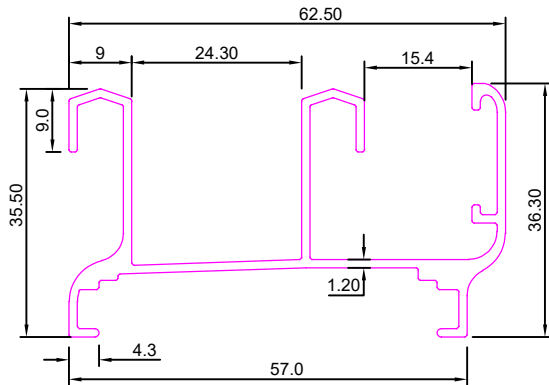

SEC No. 7266

Weight :- 2.635kg/12'

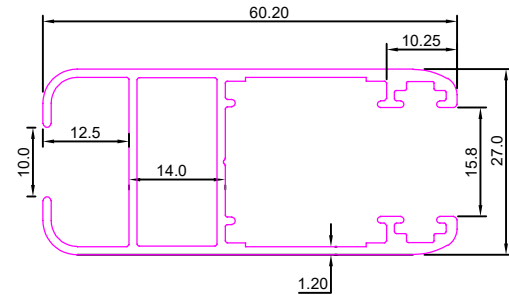

SEC No. 7285

Weight :- 8.190kg/12'

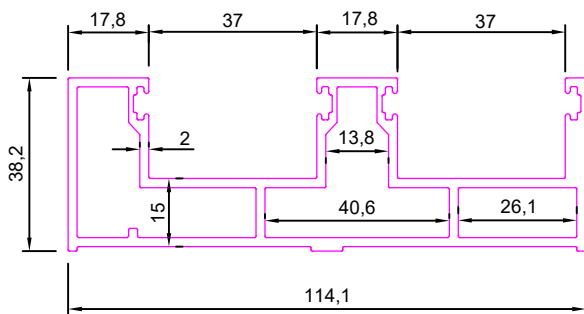

SEC No. 7286

Weight :-11.590kg/12'

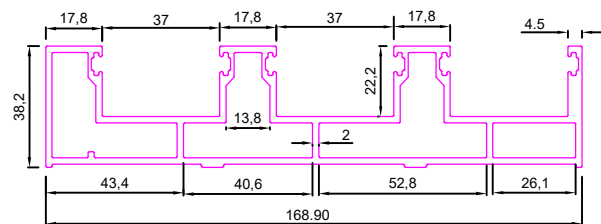



DOMAL SERIES

SEC No. 7287

Weight :- 1.100kg/12'

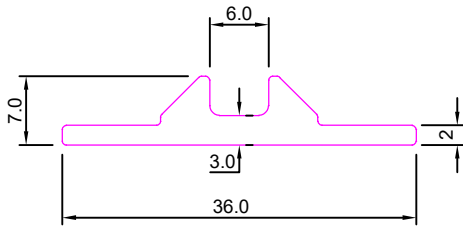

SEC No.7288

Weight :- 1.830kg/12'

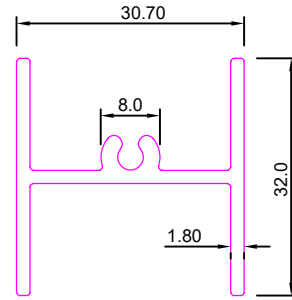

SEC No. 7289

Weight :- 1.200kg/12'

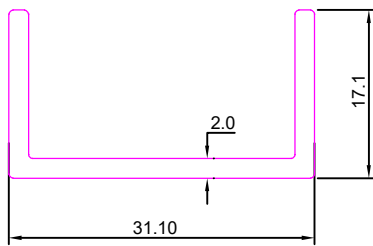

SEC No.7290

Weight :- 2.475kg/12'

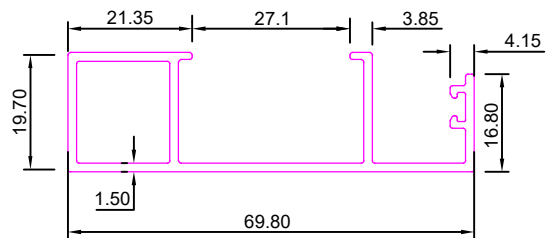

SEC No.7291

Weight :-3.100kg/12'

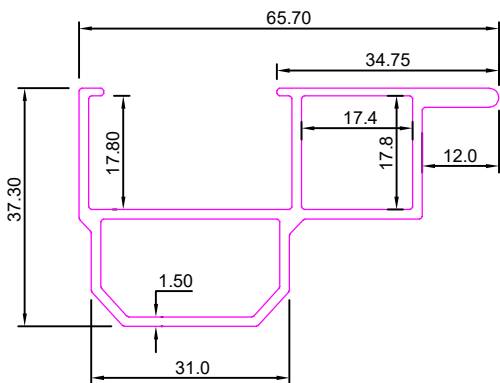

SEC No. 7292

Weight :- 1.300kg/12'

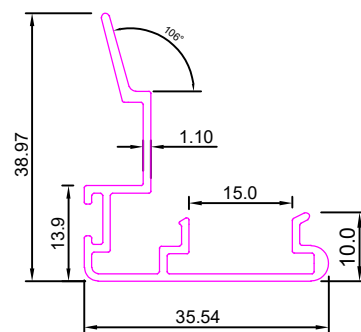



DOMAL SERIES

SEC No. 7293

Weight :- 2.600kg/12'

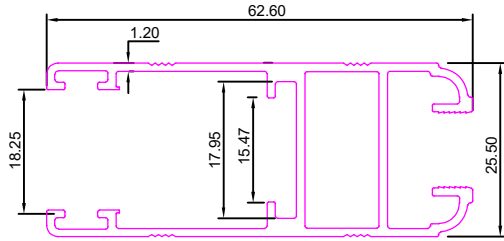

SEC No. 7294

Weight :- 2.750kg/12'

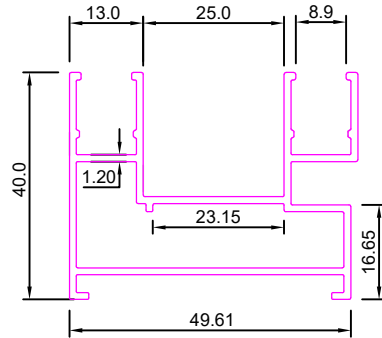

SEC No. 7295

Weight :-4.550kg/12'

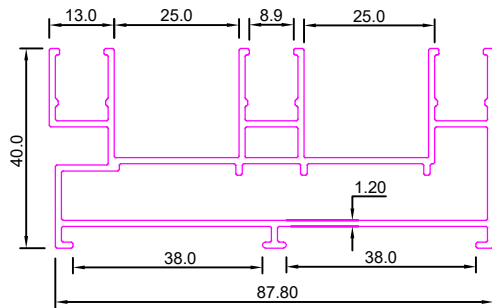

SEC No. 7296

Weight :-0.400kg/12'

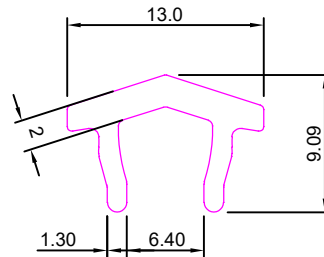

SEC No. 7297

Weight :- 1.500kg/12'

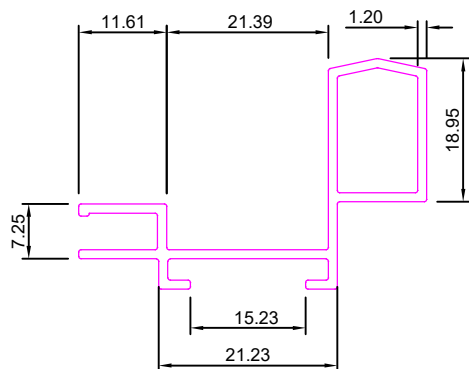

SEC No. 7298

Weight :-2.800kg/12'

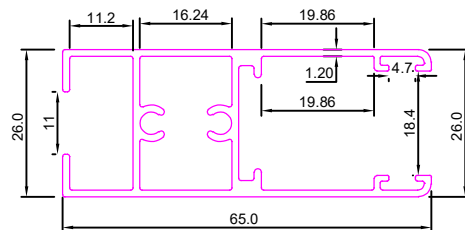



DOMAL SERIES

SEC No. 7299

Weight :-1.400kg/12'

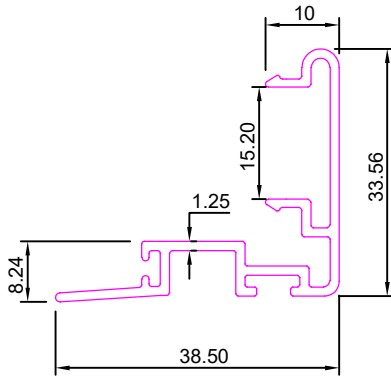

SEC No.7300

Weight :-3.600kg/12'

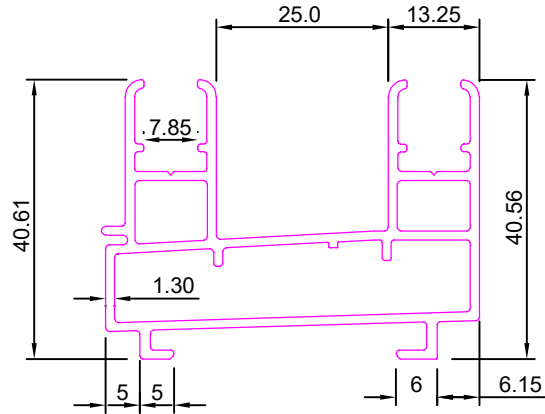

SEC No. 7301

Weight :-0.500kg/12'

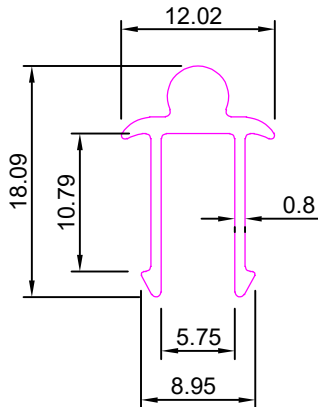

SEC No. 7302

Weight :-4.375kg/12'

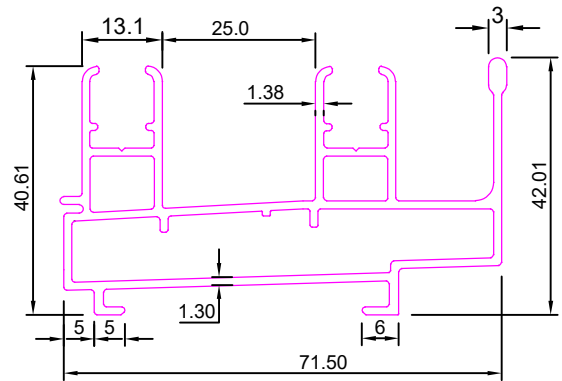

SEC No. 7303

Weight :-1.400kg/12'

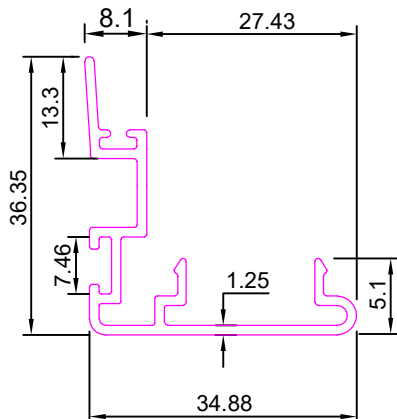

SEC No. 7304

Weight :-2.850kg/12'

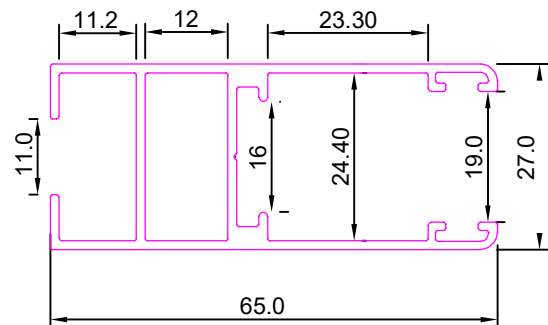



DOMAL SERIES

SEC No. 7305

Weight :-1.700kg/12'

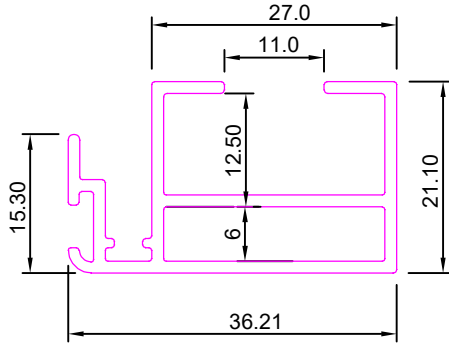

SEC No.7306

Weight :-1.730kg/12'

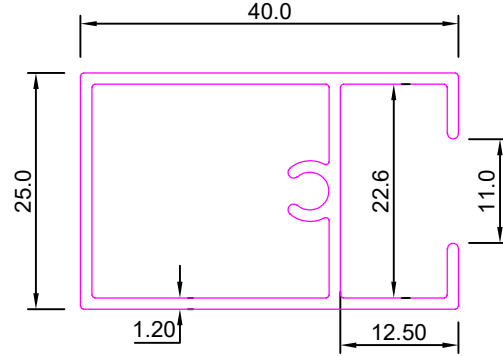

SEC No. 7307

Weight :-1.630kg/12'

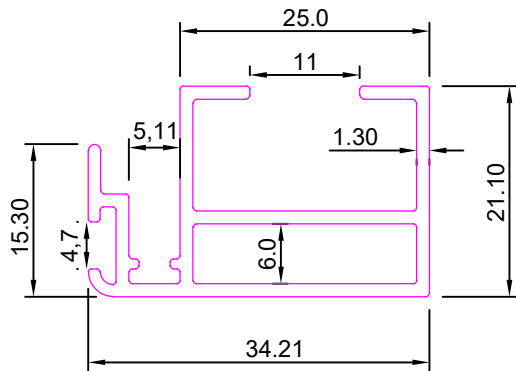

SEC No. 7308

Weight :-1.650kg/12'

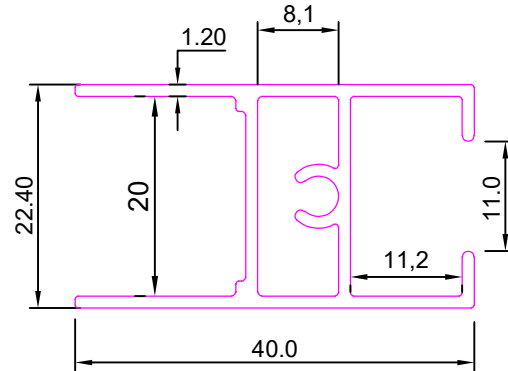

SEC No. 7349

Weight :-0.590kg/12'

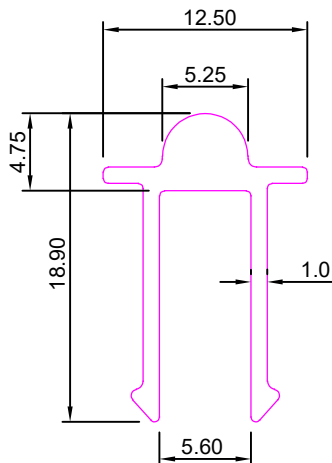

SEC No. 7350

Weight :-4.400kg/12'

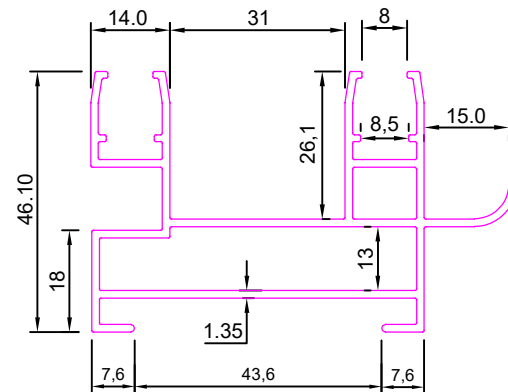



DOMAL SERIES

SEC No. 7351

Weight :-6.500kg/12'

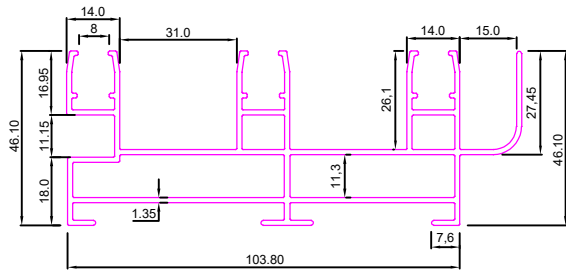

SEC No. 7379

Weight :-2.700kg/12'

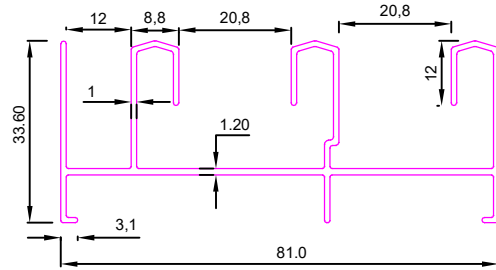

SEC No. 7380

Weight :-1.950kg/12'

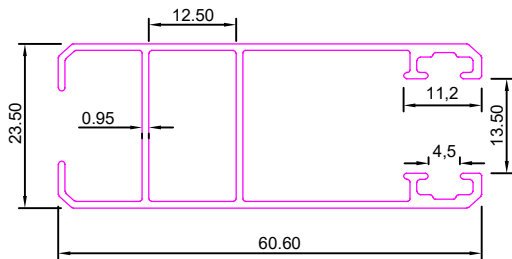

SEC No. 7381

Weight :-0.900kg/12'

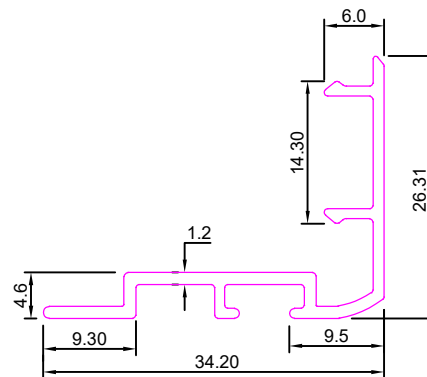

SEC No. 7384

Weight :-0.690kg/12'

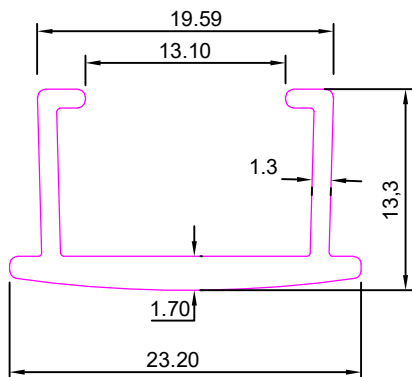

SEC No.7439

Weight :-4.00kg/12'

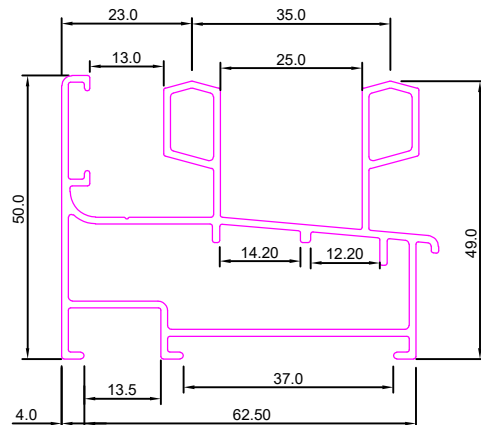



DOMAL SERIES

SEC No.7440

Weight :-5.700kg/12'

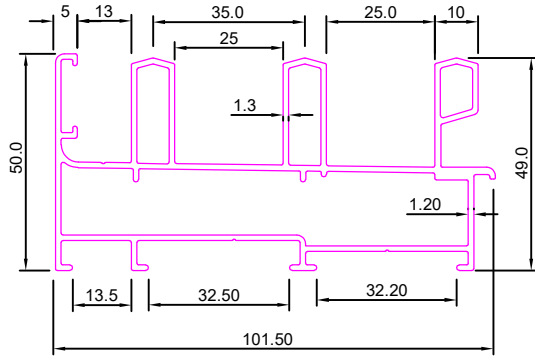

SEC No.7441

Weight :-7.975kg/12'

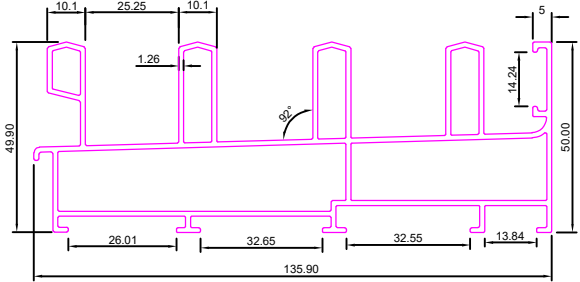

SEC No. 7453

Weight :-11.700kg/12'

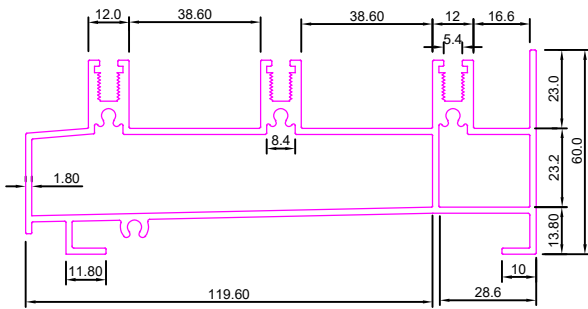

SEC No. 7486

Weight :-2.100kg/12'

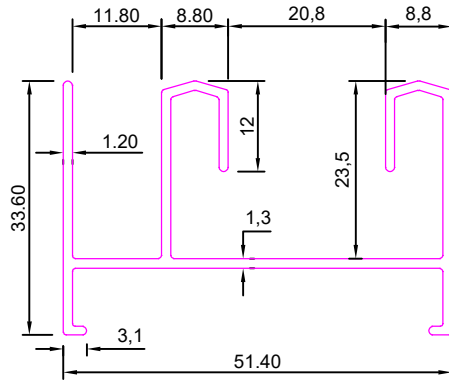

SEC. NO:-7529

Weight :- 1.720kg/12'

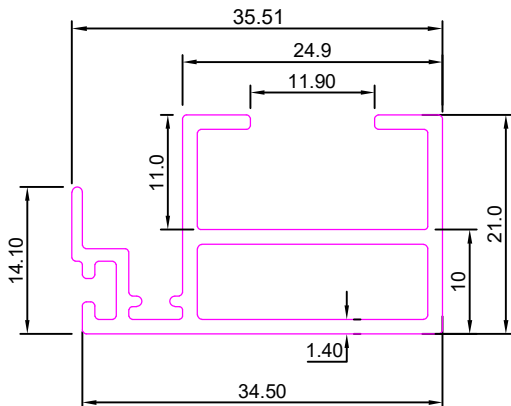

SEC. NO:-7530

Weight :- 2.375kg/12'

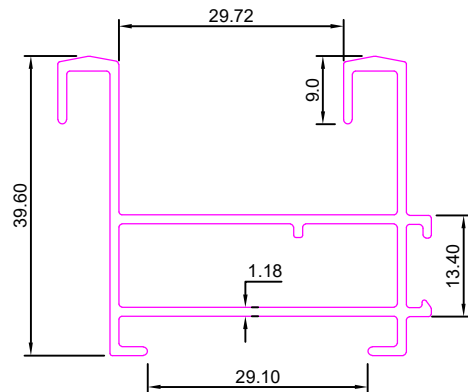



DOMAL SERIES

SEC. NO:-7531

Weight :- 3.800kg/12'

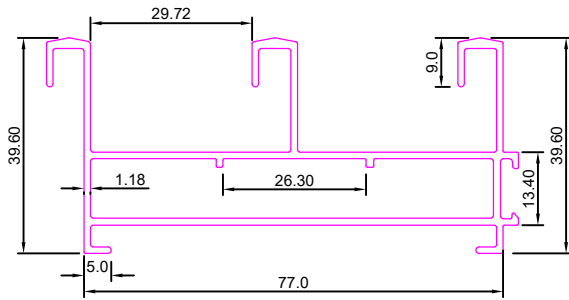

SEC. NO:-7532

Weight :- 2.614kg/12'

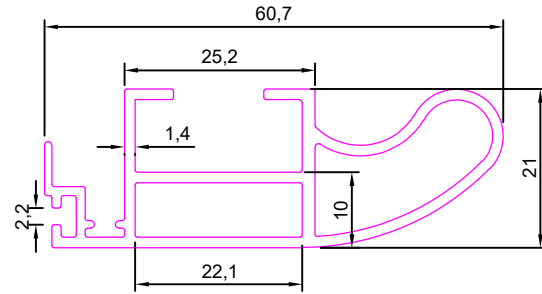

SEC. NO:-7534

Weight :-1.984kg/12'

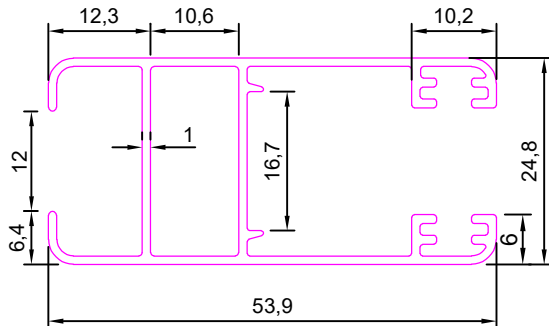

SEC. NO:-7550

Weight :-5.332kg/12'

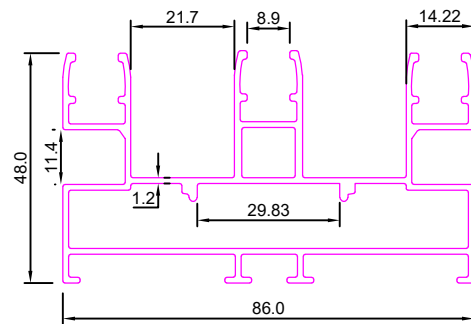

SEC. NO:-7560

Weight :- 6.120kg/12'

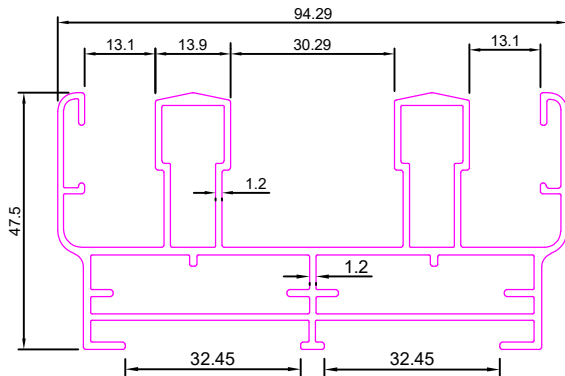

SEC. NO:-7562

Weight :- 0.350kg/12'

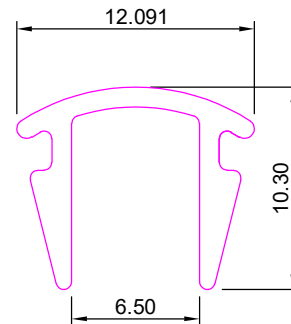



DOMAL SERIES

SEC No. 7595

Weight :- 1.000kg/12'

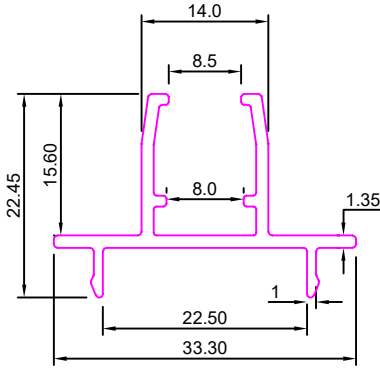

SEC No. 7608

Weight :-7.600kg/12'

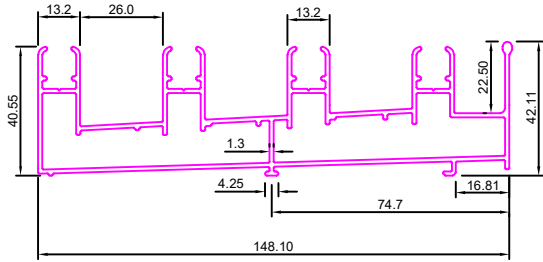

SEC No. 7614

Weight :-8.250kg/12'

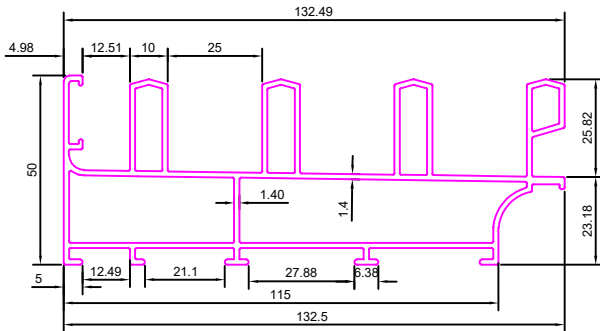

SEC No. 7640

Weight:-3.800Kg/12'

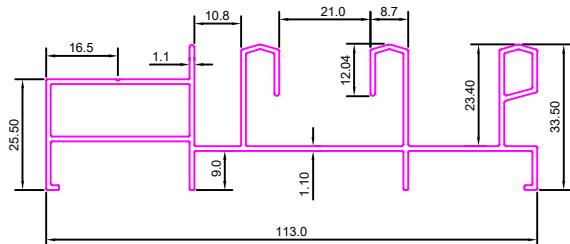

SEC No. 7641

Weight:-3.500Kg/12'

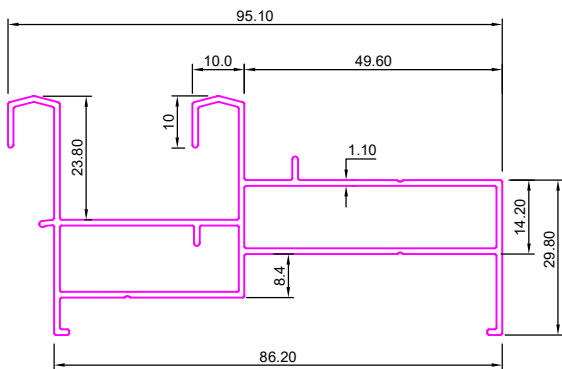

SEC No. 7688

Weight:-1.660Kg/12'

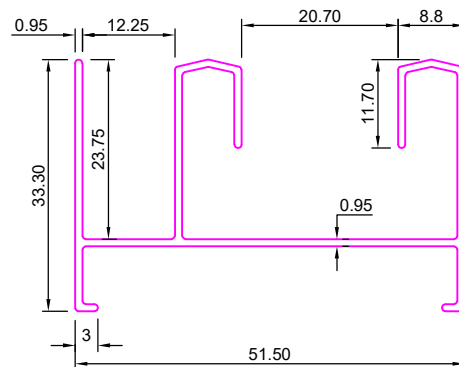



DOMAL SERIES

SEC No. 7689

Weight:-2.420Kg/12'

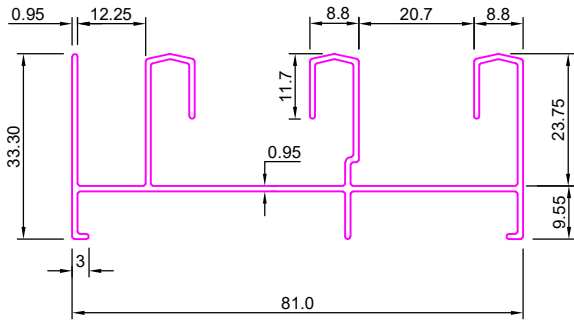

SEC No. 7690

Weight:-1.760Kg/12'

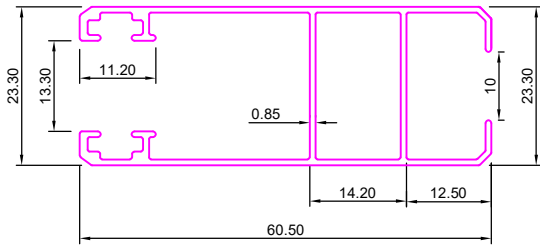

SEC No. 7691

Weight:-0.800Kg/12'

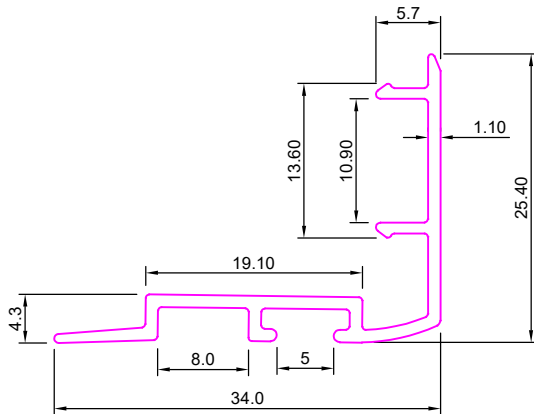

SEC No. 7728

Weight :- 3.700kg/12'

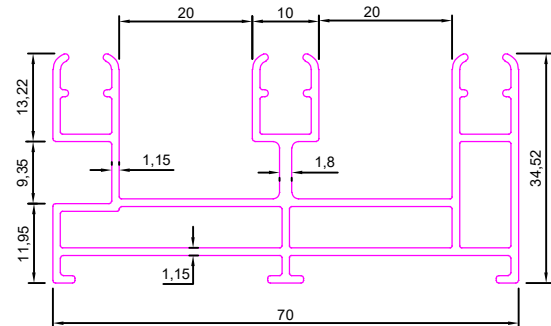

SEC No. 7729

Weight :- 2.650kg/12'

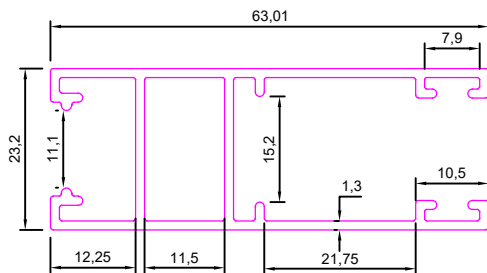

SEC No. 7730

Weight :- 0.490kg/12'

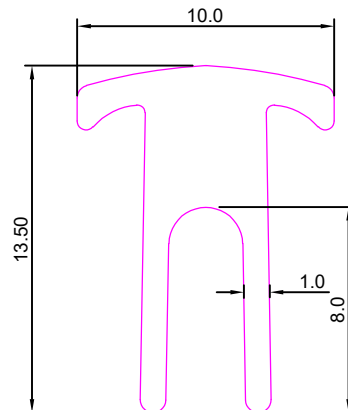



DOMAL SERIES

SEC No. 7731

Weight :- 0.815kg/12'

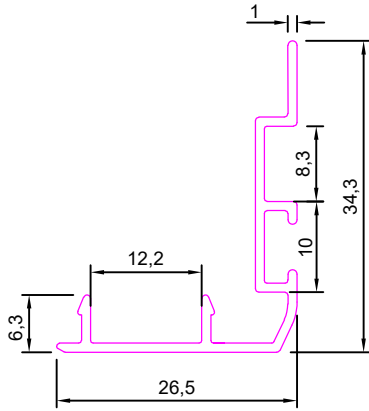

SEC No. 7783

Weight:-2.300Kg/12'

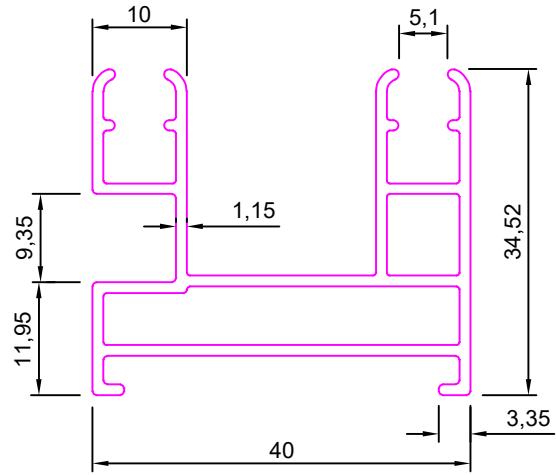

SEC No. 7785

Weight:-8.000Kg/12'

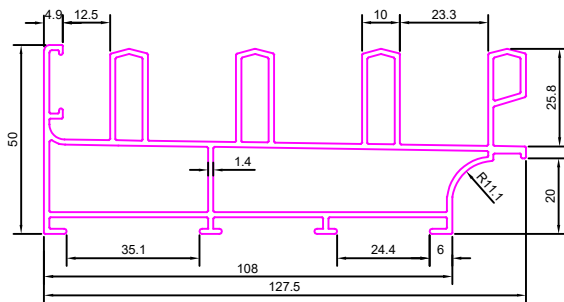

SEC No. 7830

Weight:-3.435Kg/12'

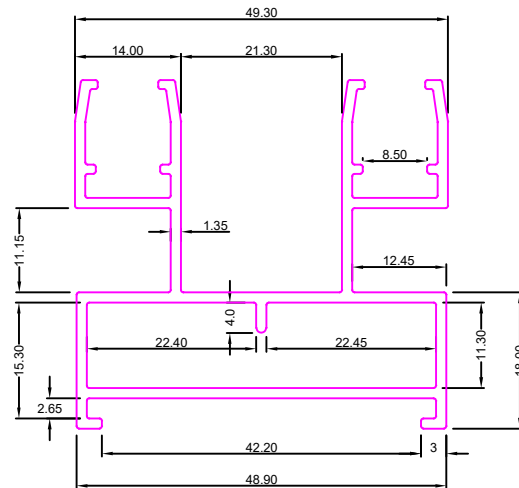

SEC No. 7831

Weight:-2.295Kg/12'

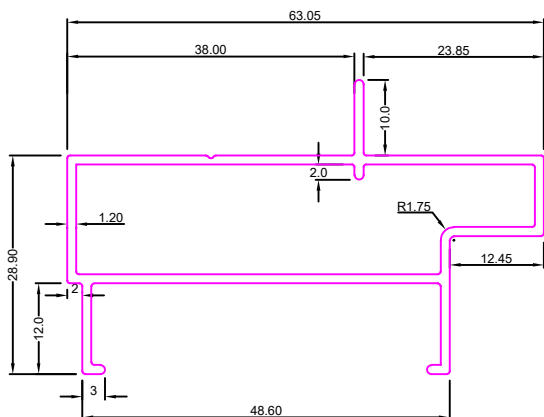

SEC No. 7838

Weight:-7.233Kg/12'

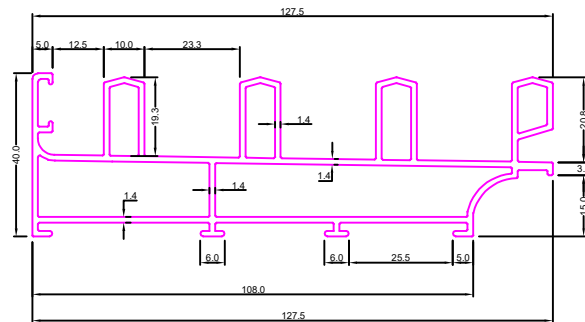



DOMAL SERIES

SEC No. 7891

Weight:-7.165Kg/12'

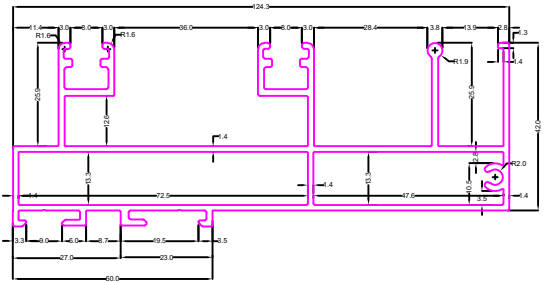

SEC No. 7892

Weight:-3.035Kg/12'

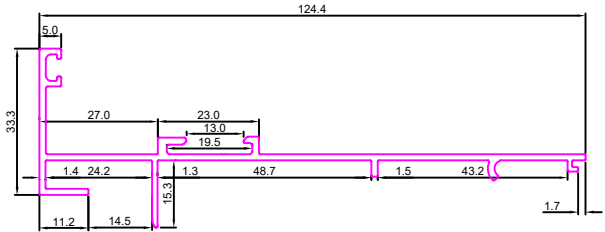

SEC No. 7896

Weight:3.192Kg/12'

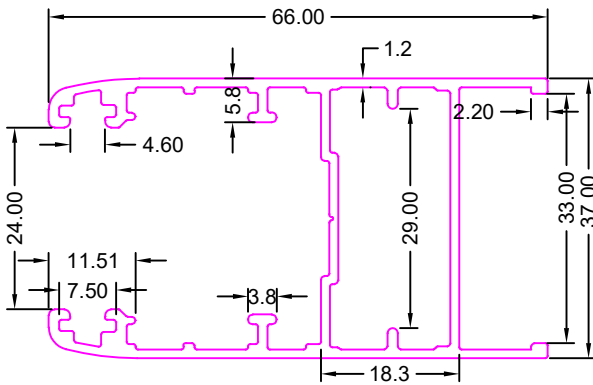

SEC No. 7897

Weight:9.600Kg/12'

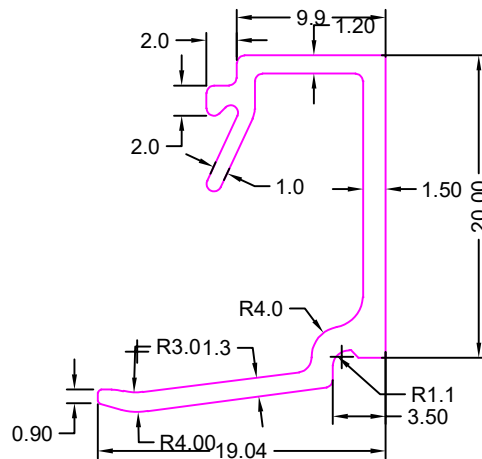

SEC No. 7898

Weight:3.275Kg/12'

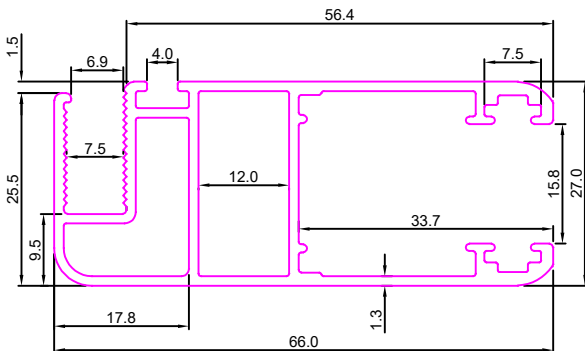

SEC No. 7912

Weight:8.075Kg/12'

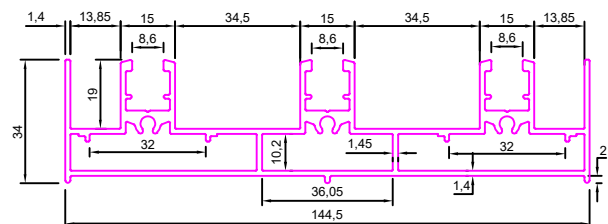



DOMAL SERIES

SEC No. 8499

Weight:-1.035Kg/12'

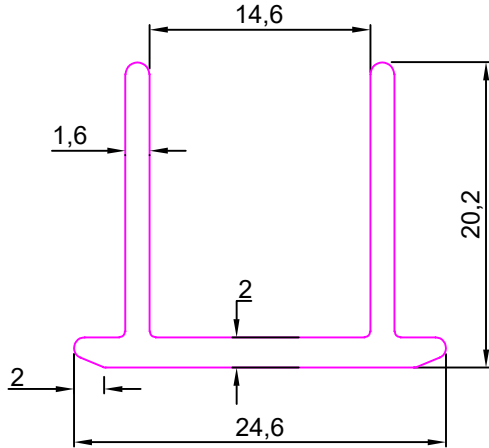

SEC No. 8500

Weight:-0.765Kg/12'

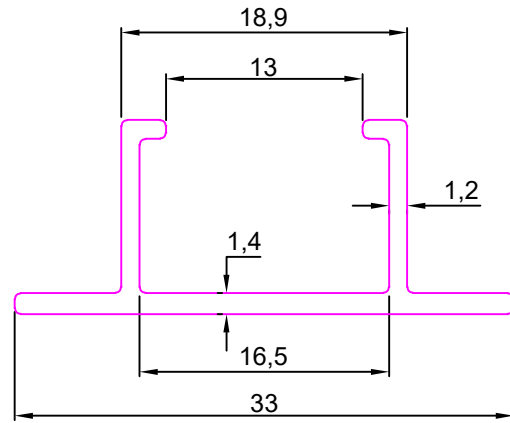

SEC No. 8504

Weight:-2.850Kg/12'

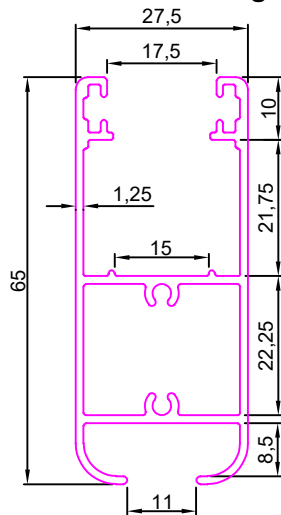

SEC No. 8505

Weight:-0.950Kg/12'

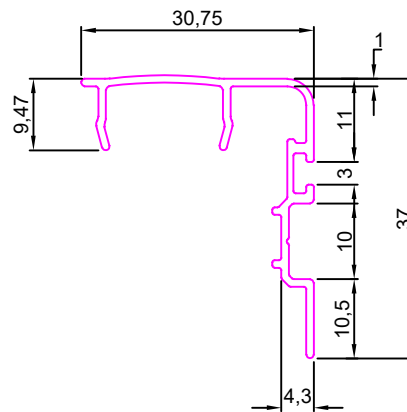

SEC No. 8506

Weight:-5.150Kg/12'

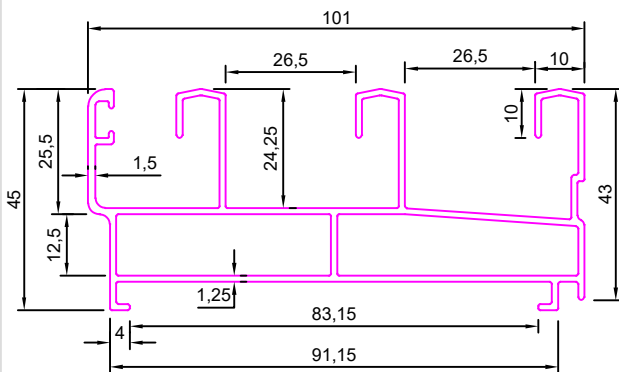

SEC No. 8507

Weight:-8.140Kg/12'

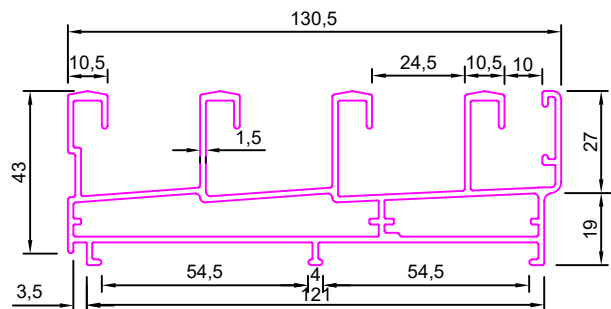



DOMAL SERIES

SEC No. 8567

Weight:5.460Kg/12'



SEC No. 8569

Weight:3.170Kg/12'

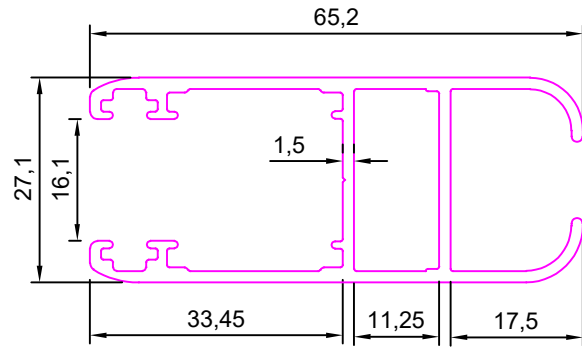

SEC No. 8570

Weight:7.050Kg/12'

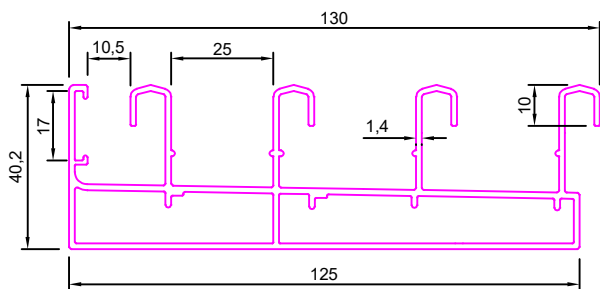

SEC No. 8571

Weight:5.680Kg/12'

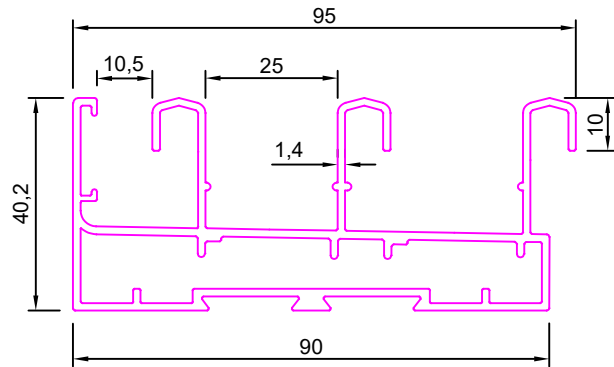

SEC No.:8816

Weight:-5.800Kg/12'

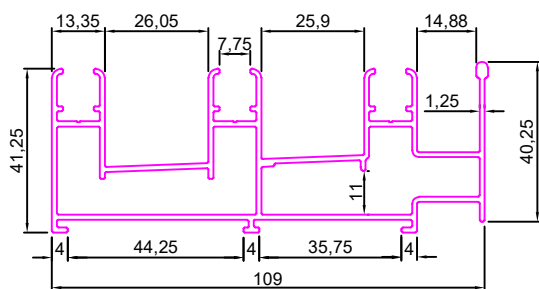

SEC No.:8817

Weight:-0.540Kg/12'

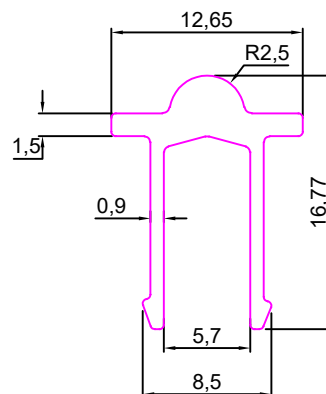



DOMAL SERIES

SEC No.:-8818

Weight:-3.850Kg/12'

